



**Kommunaltechnik  
Instandsetzung  
Fertigungs-GmbH**

Wölmsdorfer Weg 3  
14913 Niedergörsdorf  
Tel.: 033741 80 51-0  
Fax: 033741 80 51- 51  
Mail: info@kif-gmbh.com  
www.kif-gmbh.com

## Original user manual

# Add-on silo spreader

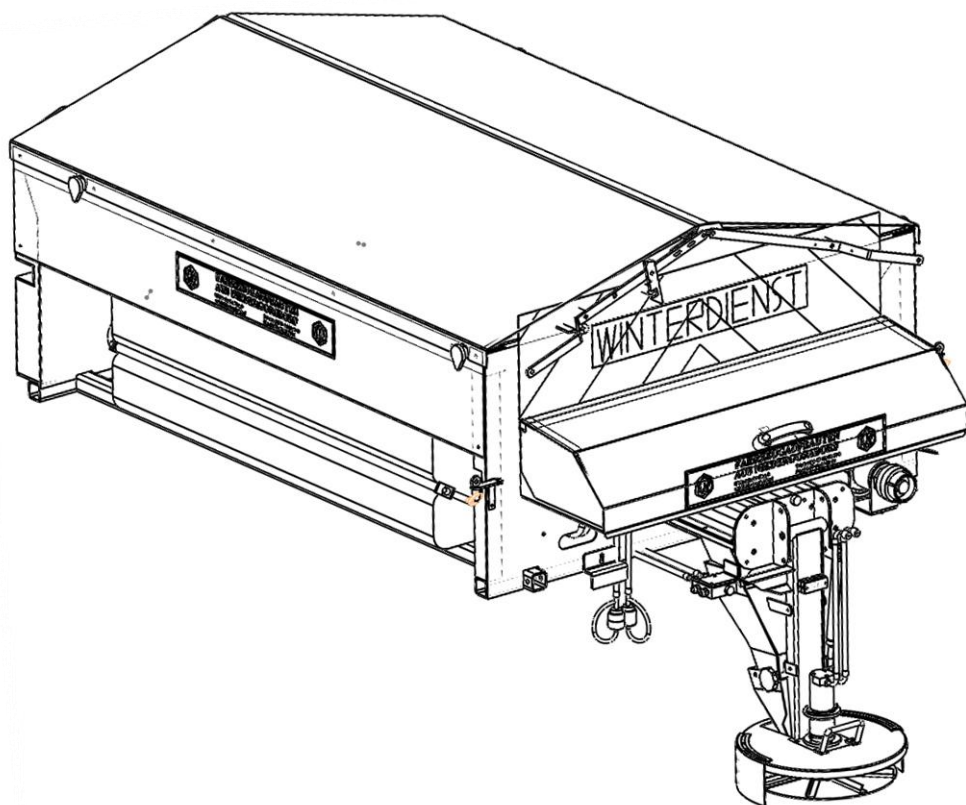

The drawing is only a freely chosen example showing a silo spreader. The drawing does not necessarily correspond to the current implementation/manufacturing series of the device supplied.



**Zertifikat**

**Certificate**



Zertifikat Nr. *Certificate No.*  
S 60101100

Blatt *Page*  
0001

Ihr Zeichen <i>Client Reference</i>	Unser Zeichen <i>Our Reference</i>	Längstens gültig bis <i>Latest expiration date</i> (day/mo/yr)
	0010-- 21228544 001	19.04.2020

**Genehmigungsinhaber *License Holder***  
Kommunaltechnik Instandsetzung  
Fertigung GmbH  
Wölmsdorfer Weg 3  
14913 Niedergörsdorf  
Deutschland

**Fertigungsstätte *Manufacturing Plant***  
Kommunaltechnik Instandsetzung  
Fertigung GmbH  
Wölmsdorfer Weg 3  
14913 Niedergörsdorf  
Deutschland

**Prüfzeichen *Test Mark***



www.tuv.com  
ID 1000000000

**Geprüft nach *Tested acc. to***  
06/42/EG - Anhang I/05.06  
EN 13021:2003+A1  
ISO 4413:2010

**Zertifiziertes Produkt (Geräteidentifikation)  
*Certified Product (Product Identification)***

**Lizenzentgelte - Einheit  
*License Fee - Unit***

Streugerät Streugerät für den Winterdienst

Bezeichnung:	10
Silostreuer: SS 200, SS 400, SS 700, SS 1000, SS 1500	
Silostreuer/Flach: SS 400/F, SS 600/F, SS 1000/F, SS 1200/F, SS 1500/F	
Feuchtsalz-Silostreuer: FSS 400/170, FSS 700/300, FSS 1000/430	
Band-Silostreuer: BSS 1000, BSS 1200, BSS 1500, BSS 2000	
Anschluss: Bordhydraulik zul. Höchstdruck 160 bar	
Streubreite: 1,5-5m	
Streugut bei Feuchtsalz: 0,5-2mm	
Streugut bei Trockensalz: 2-4mm	

10

Dem Zertifikat liegt unsere Prüf- und Zertifizierungsordnung zugrunde.  
Produkt und Fertigungsstätte erfüllen § 20 und § 21 des  
Produktsicherheitsgesetzes.  
*This certificate is based on our Testing and Certification Regulation.  
Product and production fulfill par § 20 and § 21 of the  
Product Safety Law.*

**TÜV Rheinland LGA Products GmbH, Tillystraße 2, 90431 Nürnberg**  
Tel.: +49 221 806-1371 e-mail: cert-validity@de.tuv.com  
Fax: +49 221 806-3935 http://www.tuv.com/safety

**Ausstellungsdatum *Date of Issue* : 20.04.2015 (day/mo/yr)**

**Zertifizierungsstelle**





# EU DECLARATION OF CONFORMITY

in acc. with Machinery Directive (2006/42/EC), Appendix II C

We, the manufacturer KOMMUNALTECHNIK  
INSTANDSETZUNG  
FERTIGUNGS – GmbH  
Wölmsdorfer Weg 3  
14913 Niedergörsdorf

declare under our sole responsibility that the following machine

**Silo spreader SS-.....**                      **Silo spreader / flat Type SS-...../F**

Manuf. no.: ..... Manuf. no.: .....

Year of manufacture: ..... Year of manufacture: .....

**Belt Silo spreader BSS-.....**                      **Damp salt silo spreader FSS-.....**

Manuf. no.: ..... Manuf. no.: .....

Year of manufacture: ..... Year of manufacture: .....

conforms to the provisions of the Machinery Directive and to the national legislation. The device complies with the following harmonised standards:

DIN EN ISO 13857	June	2008
DIN EN ISO 11200	October	2014
DIN EN ISO 12100	March	2011
DIN EN ISO 4413	April	2011
DIN EN 13021	April	2009
DIN EN 614-1	June	2009
DIN EN 982	June	2009
DIN EN 349	September	2008

Authorised for the compilation of the technical documentation

Diana Brachwitz  
Wölmsdorfer Weg 3  
14913 Niedergörsdorf

Niedergörsdorf, on the

.....  
Hartmut Hagedorn  
Director

### **Date of issue of user manual**

2nd Edition: November 2016

### **Copyright**

The copyright in this user manual remains with

**Kommunaltechnik, Instandsetzung, Fertigungs- GmbH**  
Wölmsdorfer Weg 3, 14913 Niedergörsdorf

This user manual is exclusively intended for the operator and the  
operator's personnel.

It contains specifications and instructions which must not be

- duplicated,
- distributed or
- communicated in any other way.

Non-compliance could result in prosecution.

### **Address of the manufacturer**

**Kommunaltechnik, Instandsetzung, Fertigungs- GmbH**

Wölmsdorfer Weg 3  
14913 Niedergörsdorf  
Tel. +49 033741 8051-0  
Fax +49 033741 / 8051-51  
info@kif-gmbh.com

The manufacturer will be referred to below as KIF GmbH.

## Table of contents

1	Basic instructions .....	8
1.1	Importance of the user manual .....	8
1.2	Intended use .....	8
1.3	Improper use .....	8
1.4	Warranty .....	9
1.5	Explanation of symbols used .....	10
1.6.	Description of the spreader .....	10
1.6.1	Conveying apparatus with shafts .....	11
1.6.2	Damp salt version .....	12
1.6.3	Conveying apparatus with transport belt .....	12
1.6.4	Schematic diagram of the silo spreader .....	13
1.6.5	Schematic diagram of the flat silo spreader .....	14
1.6.6	Schematic diagram of the damp salt silo spreader .....	15
1.6.7	Schematic diagram of the belt silo spreader .....	16
1.7	Technical data .....	17
1.7.1	Silo spreader / SS .....	17
1.7.2	Silo spreader flat / SS / F .....	19
1.7.3	Damp salt silo spreader / FSS .....	21
1.7.4	Belt silo spreader / BSS .....	23
2	Basic safety instructions .....	25
2.1	Obligation of the operator .....	25
2.2	Dangers when using the spreader .....	25
2.3	Dangers of the hydraulic equipment .....	26
2.4	Danger zones .....	26
2.5	Emissions .....	27
2.5.1	Noise .....	27
2.6	Dimensions and axle loads .....	27
2.7	Notes on maintenance, servicing and troubleshooting .....	27
2.8	Structural modifications to the spreader .....	27
3	Assembly and start-up .....	28
3.1	Assembly of the silo spreader on base vehicle with platform / device carrier .....	28
3.1.1	Supporting legs .....	29
3.1.2	Assembly of the silo spreader on base vehicle with skip loader .....	30
3.2	Disassembling the silo spreader .....	31
3.3	Transport position .....	31
3.4	Connection to the on-board hydraulic system of the carrier vehicle .....	32
3.5	Start-up .....	32
3.5.1	Adjusting the scatter pattern .....	32
3.5.2	Adjusting the gritting quantity .....	34
3.5.3	Path-dependent spread rate regulation .....	35
3.5.4	Switching off in an emergency .....	35
3.5.5	Shutting down .....	35

3.5.6	Filling procedure for the damp salt silo spreader .....	36
4	Faults .....	38
4.1	Troubleshooting .....	38
4.2	Troubleshooting the hydraulics .....	39
5	Care and inspection of the gritter .....	40
6	Maintenance and servicing .....	41
6.1	Mechanical maintenance .....	41
6.2	Hydraulic maintenance .....	41
7	Suitable operating materials and auxiliary materials .....	42
8	Disposing of the equipment .....	43
9	Technical documents .....	44
9.1	Hydraulic circuit diagram.....	44
9.1.1	Silo spreader / belt silo spreader with manual adjustment .....	44
9.1.2	Silo spreader / belt silo spreader with path-dependent spread rate control .....	45
9.1.3	Silo spreader / flat (1 chamber) with manual adjustment.....	46
9.1.4	Silo spreader / flat (1 chamber) with path-dependent spread rate control .....	47
9.1.5	Silo spreader / flat (2 chamber) /damp salt silo spreader with path-dependent spread rate control.....	48
9.1.6	Device list hydraulic silo spreader / belt silo spreader / damp salt silo spreader manual adjustment / path-dependent spread rate control ..	49
9.4	Functional description of the control unit .....	50
9.4.1	Digital controller ELMR 152 - 42 / 1, 2, 3-fold control .....	50
9.4.2	CAN BUS control module (as at 12/2013) .....	51
9.4.2.1	Structure of the controller.....	51
9.4.2.2	Spreading.....	53
9.4.3	Functional description of the start-stop mechanism .....	58
9.5	Electric circuit diagram .....	59
9.5.1	Digital controller 1 / 2 / 3-fold control .....	59
9.6	Lubrication plan.....	60
9.6.1	Silo spreader, damp salt silo spreader .....	60
9.6.2	Silo spreader / flat, damp salt silo spreader .....	61
9.6.3	Belt silo spreader.....	62
9.7	Description of the lye pump – Kappa 15 with hydraulic drive .....	63
9.7.1	Troubleshooting at the Kappa 15 membrane pump .....	64
10	Technical documents for carrier vehicle .....	65

## 1 Basic instructions

### 1.1 Importance of the user manual

The spreader may only be used and operated by trained and instructed personnel in accordance with the safety regulations. The instructed persons must have read and understood the user manual before the equipment is started up.

### 1.2 Intended use

Operation of the spreader is only permitted in the function specified by us for application in the winter.

Intended use includes the following activity:



→ **The spreader is used exclusively for spreading sand, chippings, clean salt, salt in combination with lye, or a mixture of these materials!**

Intended use also includes adhering to the installation, start-up, operating, inspection and maintenance conditions supplied by the manufacturer. It is essential that the requirements and limit values specified in the user manual are observed along with the safety instructions. Any use going beyond this constitutes a functionally inappropriate use.

If special working instructions or working conditions are necessary, it is essential to consult with and obtain written agreement from the manufacturer, in order to obtain further warranty and fairness claims.

Local rules, regulations and bylaws laid down by district, communities and municipal authorities for the spreading of grit must be complied with appropriately!

### 1.3 Improper use

The following are considered as functionally improper use, and are therefore not permitted:

- **Spreading of bulk materials where the grain size exceeds 8 mm,**
- **Spreading of fertilisers or similar,**
- **Spreading other functionally inappropriate materials and grits.**











## 1.4 Warranty

### **Our general conditions of sale and delivery generally apply!**

The manufacturer only guarantees trouble-free operation if the specifications in the user manual are observed and if use of the spreader is functionally appropriate. The manufacturer shall not be liable for damage caused as a result of improper and inappropriate use or operation of the spreader.

Failure to observe the specifications and rules of conduct in relation to the user manual also results in the warranty and guarantee becoming void. Warranty and guarantee claims to the manufacturer are excluded if the construction or function of the equipment or device was or is modified without written consent from the manufacturer.

### 1.5 Explanation of symbols used

Safety instructions (Personal injury is possible!)			
Symbol	Signal word	Meaning	Possible damage
 Warnung	Warning	Potentially imminent danger	Serious injury
 Vorsicht	Caution	Potentially dangerous situations	Slight injuries or damage
 Achtung	Attention	Potentially dangerous situations	Damage to the device or its surroundings
	Important	Useful tips for optimum operation	Non-compliance can lead to system malfunctions
	Attention	Risk of entanglement by rollers	Serious injury
	Attention	Read the user manual!	Non-compliance can lead to system malfunctions and injuries
	Attention	Warning – chain drive!	Serious injury

### 1.6. Description of the spreader

The spreader has been designed so that grit can quickly and easily be distributed evenly over the surface to be gritted. The equipment comprises the following primary components:

- base frame structure
- spreader container
- lye tank (damp salt version)
- conveying apparatus for grit (shaft or conveyor belt)
- disc assembly

The silo spreader consists of a spreader container and a lower frame structure. The conveying apparatus differs in one respect through having a conveyor belt or having one or two discharge shafts (**Registered Design No.: 20 2014 003 917.8**).

A material funnel is located at the end of the conveying apparatus, passing the grit precisely to the spreader plate. The spreader plate distributes the grit to the various ranges in accordance with the set rotation speed. The spreader plate assembly is built with a rotating spreader plate that is covered by a protective device. However, in the area of the material feed and in the discharge area, the spreader plate can only be covered over a certain area, enough to ensure further function of the device.



**Operation of the spreader without the protective device is forbidden!**

The spreader is supplied and operated by means of the on-board hydraulics of the carrier vehicle. Care was taken when designing the spreader to ensure that a suitable, secure fastening device is used for any vehicle platform and for any container vehicle.

Another big advantage of this design is that a container vehicle, which is particularly suitable for container transport, can also be used in winter operation with the spreader.

### 1.6.1 Conveying apparatus with shafts

The spreader container of the silo spreader consists of one chamber, or optionally of two. A discharge shaft (worm shaft) for the grit is found in each chamber of the spreader container, in addition to one or two agitator shafts (if ordered) which are fitted with screw-on tappets to stop the formation of bridges.

To avoid the formation of bridges in the spreader container with various types of grit, we offer the following screw-on tappets for the agitator shafts:

Universal grit	V-shaped	tappet height = 50 mm
Non-pourable grit	V-shaped	tappet height = 70 mm
Chippings	I-shaped	tappet height = 50 mm

The discharge shaft and the agitator shaft are chain-driven.

**A chain guard prevents contact with the chain and the chain wheels.**



**The hydraulics must be switched off and depressurised when working on the chain drive; the vehicle must be switched off and the ignition key withdrawn.**

### 1.6.2 Damp salt version

The damp salt apparatus is used exclusively for adding lye to dry salt. A lye nozzle sprays the dry salt falling into the material funnel before it meets the spreader plate. The damp salt silo spreader consists of the spreader container, wherein two lye containers are integrated into the structure of the base frame. One or two discharge shafts (worm shafts) for discharging the grit, as well as one or two agitator shafts to avoid the formation of bridges in the grit, are located in the spreader container.



**The grit must always be dry and pourable!  
A grain size of 2-4 mm is ideal.**

### 1.6.3 Conveying apparatus with transport belt

The spreader container of the belt silo spreader consists of one chamber. A hydraulically driven conveyor belt is located in the spreader container.



**The grit must always be dry and pourable!  
A grain size of 2-4 mm is ideal.**

### 1.6.4 Schematic diagram of the silo spreader

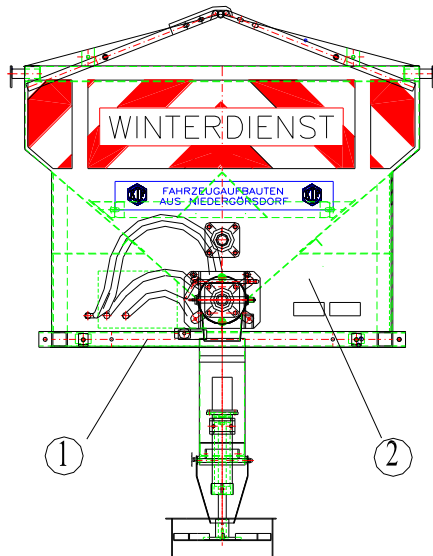

Disc assembly as from 06/2015

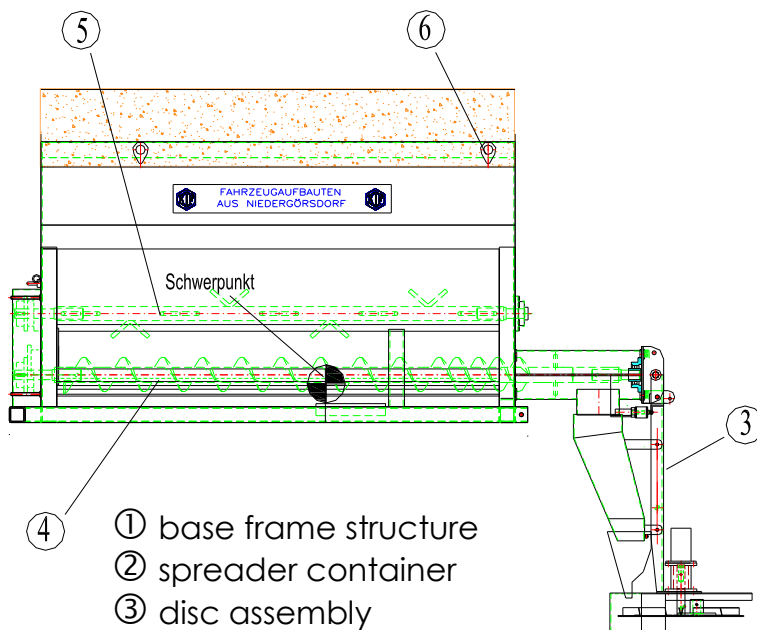
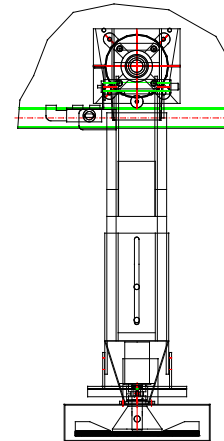

Disc assembly as from 06/2015

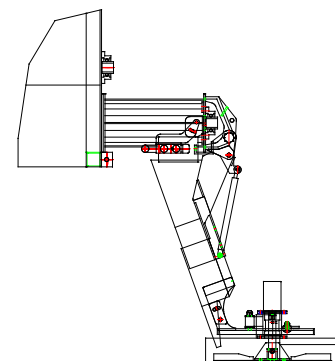

- ① base frame structure
  - ② spreader container
  - ③ disc assembly
  - ④ discharge shaft for grit
  - ⑤ agitator shaft for grit
  - ⑥ container brackets
- Schwerpunkt = Centre of gravity

1.6.5 Schematic diagram of the flat silo spreader

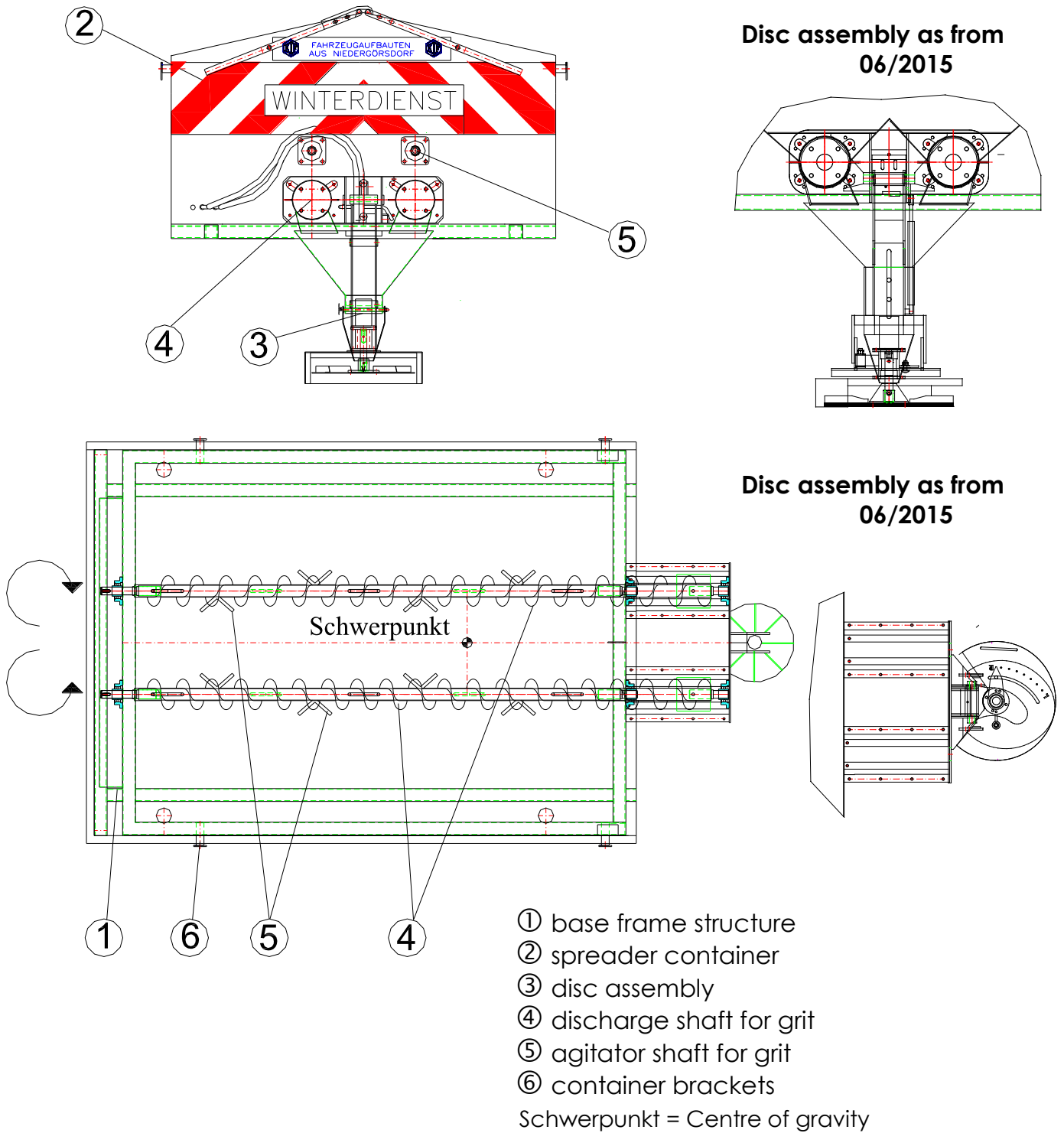

### 1.6.6 Schematic diagram of the damp salt silo spreader

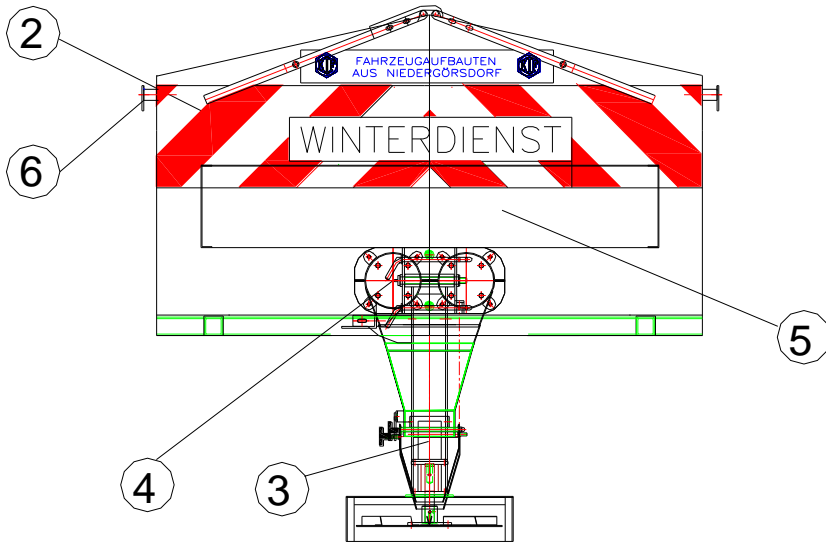

Disc assembly as from 01/2017

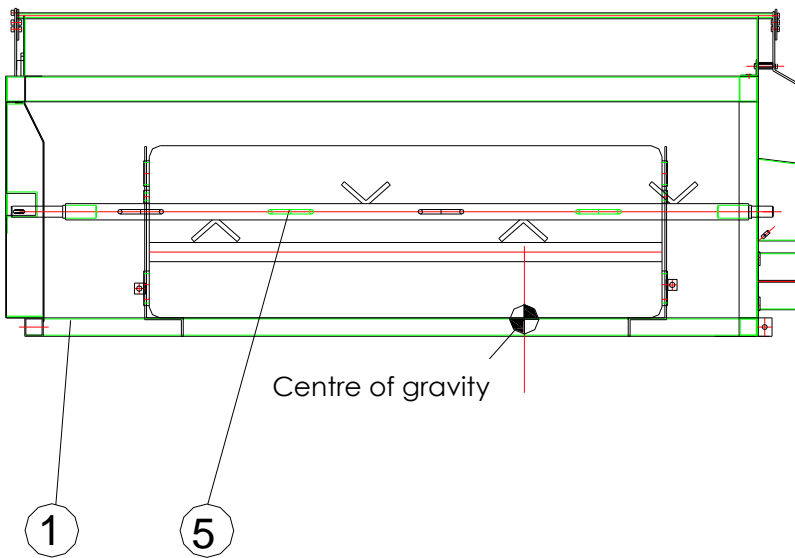
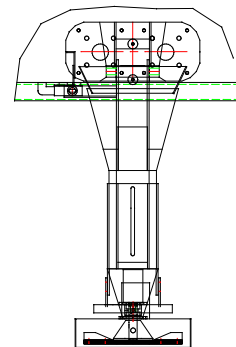

Disc assembly as from 01/2017

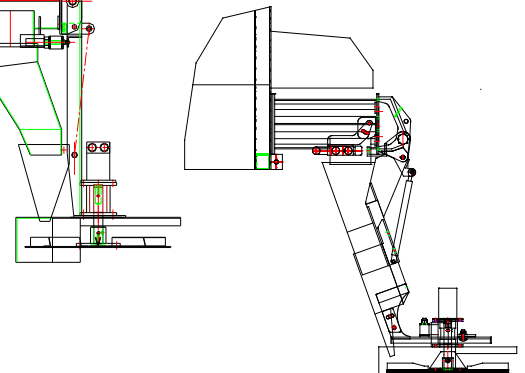

- ① base frame structure
- ② spreader container
- ③ disc assembly
- ④ discharge shaft for grit
- ⑤ agitator shaft for grit
- ⑥ container brackets

### 1.6.7 Schematic diagram of the belt silo spreader

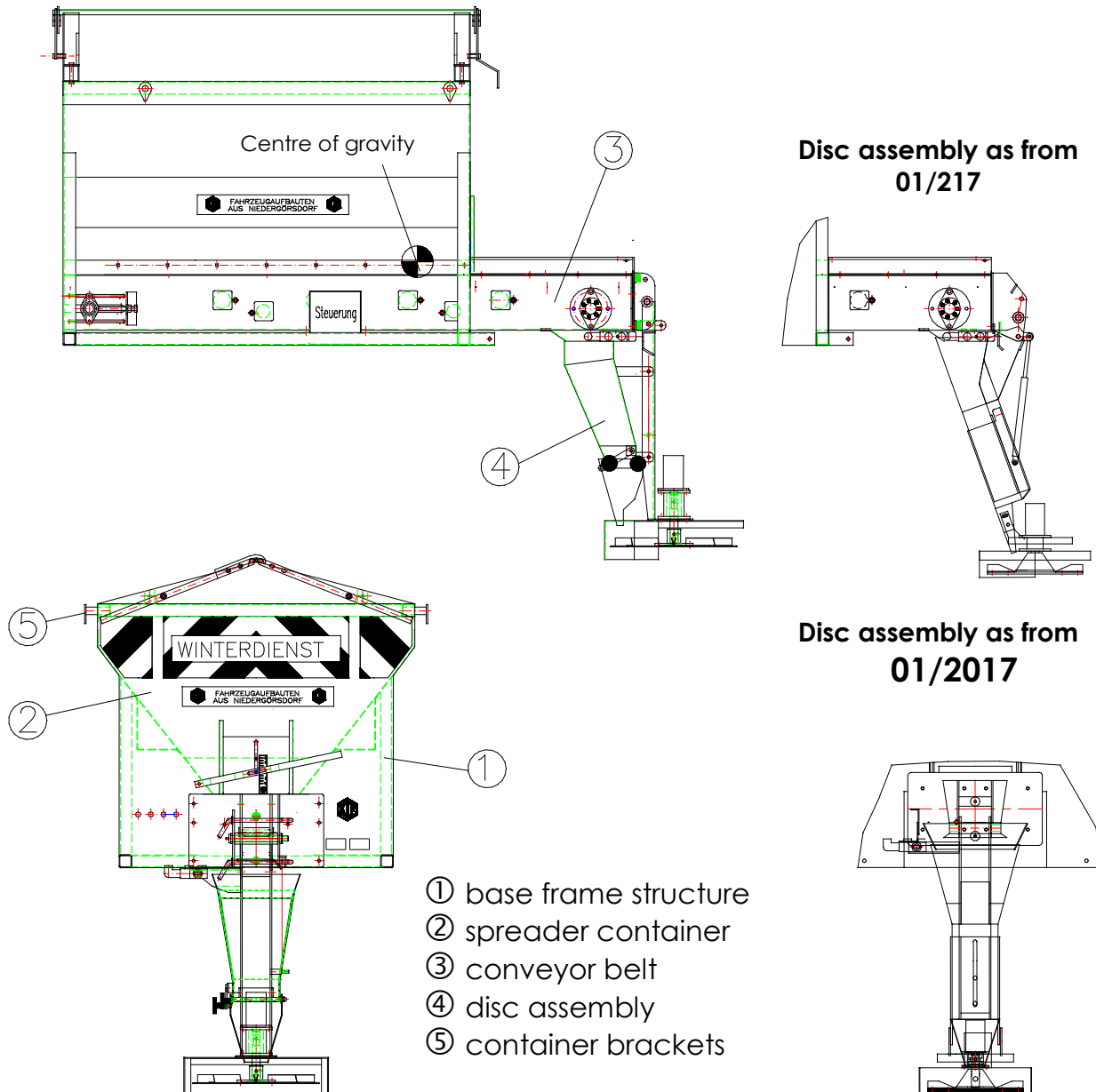







**1.7 Technical data**

**1.7.1 Silo spreader / SS**

**Rating plate:**

 <p><b>KOMMUNALTECHNIK INSTANDSETZUNG FERTIGUNGS-GMBH</b></p> <p>Wölmsdorfer Weg 3 • 14913 Niedergörsdorf Tel. (03 37 41) 80 51 0</p>		
Type	Silo spreader	 
Dimensions (see table for size)		
Manufacturing No.....		
Year of manufacture: .....		
Weight	(see table)	

<b>Perm. ambient temperature:</b>	-20° C to +20° C
<b>Max. grain size being scattered:</b>	2 to 4 mm
<b>Drive:</b>	Hydraulic drive
<b>Controller:</b>	Manual adjustment / path-dependent adjustment available as an option
<b>Spreading range:</b>	approx. 1.50 to 5.00 metres
<b>Gritting quantity:</b>	approx. 10 – 240g/m <sup>2</sup> , depending on the grit
<b>Load capacity of the carrier vehicle:</b>	Observe the max. perm. useful load/total weight of the carrier vehicle!
<b>Minimum configuration of the carrier vehicle:</b>	Hydraulic system min. 120 bar Hydraulic connections rear Rotating beacon
<b>Oil pressure/oil flow required from the hydraulic system:</b>	160 bar / 20 – 35 l/min
<b>Versions:</b>	Silo spreader for flatbed vehicles / device carrier Silo spreader for container mounting Silo spreader - long version <b>See table of technical data on page 18</b>

**Technical data**

<b>Silo spreader</b>	<b>SS-200</b>	<b>SS-400</b>	<b>SS-700</b>	<b>SS-1000</b>	<b>SS-1200</b>	<b>SS-1500</b>
Container length (mm)	1200	1250	1750	1500	1500	2100
Container width (mm)	700	1000	1250	1250	1250	1250
Height without tarpaulin frame (mm)	500	700	710	890	990	990
Height with tarpaulin frame (mm)	600	860	890	1070	1170	1170
Weight (kg)	180	250	400	345	355	480
Container volume (l)	200	400	700	1000	1200	1500
Discharge length (mm)	300	300	400	400	400	400

**1.7.2 Silo spreader flat / SS / F**

**Rating plate:**

 <p><b>KOMMUNALTECHNIK INSTANDSETZUNG FERTIGUNGS-GMBH</b></p> <p>Wölmsdorfer Weg 3 • 14913 Niedergörsdorf Tel. (03 37 41) 80 51 0</p>	
Type	Silo spreader/flat
Dimensions	(see table for size)
Manufacturing No.	.....
Year of manufacture	.....
Weight	(see table)







- |  |  |
|--|--|
| <b>Perm. ambient temperature:</b>                                | -20° C to +20° C   |
| <b>Max. grain size being scattered:</b>                          | 2 to 4 mm  |
| <b>Drive:</b>  | Hydraulic drive  |
| <b>Controller:</b>   | Manual adjustment / path-dependent adjustment available as an option   |
| <b>Scatter range:</b>  | approx. 1.50 to 5.00 metres  |
| <b>Gritting quantity:</b>  | approx. 5 – 240g/m <sup>2</sup> , depending on the grit  |
| <b>Load capacity of the carrier vehicle:</b>                     | Observe the max. perm. useful load/total weight of the carrier vehicle!  |
| <b>Minimum configuration of the carrier vehicle:</b>             | Hydraulic system min. 120 bar<br>Hydraulic connections rear<br>Rotating beacon   |
| <b>Oil pressure/oil flow required from the hydraulic system:</b> | 160 bar / 20 - 35 l/min  |
| <b>Versions:</b>   | Silo spreader for flatbed vehicle / device carrier<br>Silo spreader with external drive<br><b>See table of technical data on page 20</b> |

**Technical data**

<b>Silo spreader / flat</b>	<b>SS-400/F</b>	<b>SS-600/F</b>	<b>SS-1000/F</b>	<b>SS-1000/F</b>	<b>SS-1200/F</b>	<b>SS-1500/F</b>
Container length (mm)	1250	1500	1500	1750	2050	2050 / 2550
Container width (mm)	1000	1000	1250	1250	1500	1500
Height without tarpaulin frame (mm)	550	650	710	600	710	810/710
Height with tarpaulin frame (mm)	710	750	890	780	890	880/890
Weight (kg)	290	300	400	395	515	540
Container volume (l)	400	600	1000	1000	1200	1500
Discharge length (mm)	300	300	400	400	400	400

**1.7.3 Damp salt silo spreader / FSS**

**Rating plate:**

	<p><b>KOMMUNALTECHNIK INSTANDSETZUNG FERTIGUNGS-GMBH</b></p> <p>Wölmsdorfer Weg 3 • 14913 Niedergörsdorf Tel. (03 37 41) 80 51 0</p>
<p>Type      Damp salt silo spreader</p> <p>Dimensions (see table for size)</p> <p>Manufacturing No. ....</p> <p>Year of manufacture .....</p> <p>Weight      (see table)</p>	  

<b>Perm. ambient temperature:</b>	-20° C to +20° C
<b>Max. grain size being scattered:</b>	0.5 to 2.0 mm
<b>Drive:</b>	Hydraulic drive
<b>Controller:</b>	path-dependent adjustment
<b>Scatter range:</b>	approx. 1.50 to 5.00 metres
<b>Gritting quantity:</b>	approx. 5 – 120g/m <sup>2</sup> , depending on the grit
<b>Salt lye gritting quantity:</b>	0 – 30 % of the dry material (F30)
<b>Load capacity of the carrier vehicle:</b>	Observe the max. perm. useful load/total weight of the carrier vehicle!
<b>Minimum configuration of the carrier vehicle:</b>	hydraulic system min. 120 bar Hydraulic connections rear Rotating beacon
<b>Oil pressure/oil flow required from the hydraulic system:</b>	160 bar / 20 - 35 l/min
<b>Versions:</b>	Damp salt silos spreader for flatbed vehicles/ device carrier <b>See table of technical data on page 22</b>

**Technical data**

<b>Damp salt silo spreader</b>	<b>FSS-400/170</b>	<b>FSS-700/300</b>	<b>FSS-1000/430</b>
Container length (mm)	920	1750	2050
Container width (mm)	1200	1250	1500
Height without tarpaulin frame (mm)	800	710	710
Height with tarpaulin frame (mm)	900	890	890
Weight (kg)	380	450	640
Container volume dry material (l)	400	700	1000
Container volume lye (l)	170	300	430
Discharge length (mm) without disc assembly	300	400	400

**1.7.4 Belt silo spreader / BSS**

**Rating plate:**

 <p><b>KOMMUNALTECHNIK INSTANDSETZUNG FERTIGUNGS-GMBH</b></p> <p>Wölmsdorfer Weg 3 • 14913 Niedergörsdorf Tel. (03 37 41) 80 51 0</p>	
Type            Belt silo spreader Dimensions (see table for size) Manufacturing No. .... Year of manufacture ..... Weight            (see table)	   

<b>Perm. ambient temperature:</b>	-20° C to +20° C
<b>Max. grain size being scattered:</b>	2 to 4 mm
<b>Drive:</b>	Hydraulic drive
<b>Controller:</b>	Manual adjustment / path-dependent adjustment available as an option
<b>Scatter range:</b>	approx. 1.50 to 5.00 metres
<b>Gritting quantity:</b>	approx. 10 – 240 g/m <sup>2</sup> , depending on the grit
<b>Load capacity of the carrier vehicle:</b>	Observe the max. perm. useful load/total weight of the carrier vehicle
<b>Minimum configuration of the carrier vehicle:</b>	Hydraulic system min. 120 bar Hydraulic connections rear Rotating beacon
<b>Oil pressure/oil flow required from the hydraulic system:</b>	160 bar / 20 l/min
<b>Versions:</b>	Belt silo spreader for flatbed vehicles / device carrier <b>See table of technical data on page 24</b>

**Technical data**

<b>Belt silo spreader</b>	<b>BSS-1000</b>	<b>BSS-1200</b>	<b>BSS-1500</b>	<b>BSS-2000</b>
Container length (mm)	1600	1600	2000	2600
Container width (mm)	1250	1250	1250	1500
Height without tarpaulin frame (mm)	790	1030	1030	950
Height with tarpaulin frame (mm)	955	1195	1195	1115
Weight (kg)	350	450	500	680
Discharge length (mm) without disc assembly	400	400	400	400



## 2 Basic safety instructions

### 2.1 Obligation of the operator

The spreader may only be used and operated independently by approved and authorised persons who:

- are physically and mentally capable.
- would be expected to carry out the tasks assigned to them reliably and conscientiously.
- have been instructed and trained in how to operate the spreader and its components.
- have read and understood the user manual and are in possession a written order from the contractor or operator for the use of the spreader.



It must, furthermore, be borne in mind that

- the user manual is always to be kept at or close to the spreader or vehicle.
- in addition to the user manual, any relevant local rules and regulations from the operator in relation to accident prevention must be observed.
- the general safety and accident prevention regulations must be complied with everywhere. all safety instructions and hazard warnings are to be kept in a visible, easily legible condition at the spreader.
- when spreading, the vehicle carries identifying signals (rotating beacon, lighting equipment), and that its function is monitored.

### 2.2 Dangers when using the spreader

The KIF GmbH spreader has been designed and built according to the accepted rules of good engineering practice.

There may nevertheless be danger to life and limb of the user or third parties, or impairments of the mechanical system or other material assets, if the equipment is operated and used improperly.

It is therefore essential for use of the device that the user manual is complied with!

**The spreader is intended exclusively for this use:**



- to be operated for the functionally correct purpose specified by the manufacturer.
- This includes keeping the spreader in a proper, safe condition.



**If the operational safety of the spreader is not guaranteed as a result of a fault or damage, the equipment must be taken out of operation immediately, and not started up again until all the faults and damage have been properly rectified.**

**2.3 Dangers of the hydraulic equipment**



- The spreader must only be operated using proper couplings of the vehicle that are approved for the operating pressure.
- Work on the hydraulic equipment of the spreader, and on the hydraulic components located there, must only be carried out by trained personnel.
- The hydraulics must be switched off and depressurised when working on the vehicle or spreader; the vehicle must be switched off and the ignition key withdrawn.
- The hydraulic system must be disconnected for this and safeguarded against unauthorised activation!
- Before starting work, make sure that the hydraulic equipment is depressurised.
- Hydraulic oil at high pressure can be forced under the skin. Consult a doctor immediately in case of injury!

**2.4 Danger zones**



- Reaching into or over the spreader, or stepping through it, is forbidden when it is in an operating state or stationary!
- Do not handle objects on the inside or outside area of the spreader when it is in the operating state!
- Safety covers are not to be removed when the spreader is in or before operation!
- Watch out for grit that is thrown out!
- Pay attention to moving and rotating components above all!
- It is forbidden to remain in the spraying and spreading region.

## 2.5 Emissions

### 2.5.1 Noise

Noise (noise emissions) only arise at the spreader as a result the drive to the individual conveying equipment and spreading equipment for the grit. The continuous sound pressure level of the silo spreader has been measured as less than 70 dB(A).

## 2.6 Dimensions and axle loads

When the spreader is attached, the vehicle dimensions, the axle loads and the permissible total weight of the carrier vehicle are changed. This must be taken into account by the user of the spreader vehicle, and special attention should be paid to the permissible axle loads when full of grit.



**In spite of all the attachments at the front and rear, the permissible total weight, and the axle loadings of the carrier vehicle, must not be exceeded.**

## 2.7 Notes on maintenance, servicing and troubleshooting



**Achtung**

- Prescribed servicing and inspection work must be carried out by trained and instructed specialist personnel in accordance with the schedule specified by the manufacturer.
- The vehicle must be switched off, and the hydraulic system must be depressurised, for all maintenance, inspection and repair work.
- When the work is complete, a test run of the engineering equipment should be carried out with the greatest of care and attention to check the correctness.
- The function of all the electronic and lighting equipment must be checked.
- Warning signs and lettering on the vehicle and on the spreader must be checked for legibility and cleanliness.

## 2.8 Structural modifications to the spreader



**Warnung**

- No changes may be made to attachments or modifications of the spreader or of the carrier vehicle without the written approval of the manufacturer, KIF GmbH!



- It is essential that any modifications to the spreader have the written agreement of the manufacturer, KIF GmbH.
- Wrongful actions or procedures can have legal consequences!
- Claims for guarantee or warranty also become void if the goods as shipped by the factory are changed.
- Machine parts or assemblies that are not in proper condition must be exchanged immediately by trained, specialist personnel in order to ensure continued functional safety!
- Only original replacement and consumable parts that accord with the manufacturer's technical documentation are to be used!

### 3 Assembly and start-up

#### 3.1 Assembly of the silo spreader on base vehicle with platform / device carrier

The rear of the carrier vehicle must be removed, and the side boards must be folded down. Using lifting gear, bring the silo spreader up to about the level of the platform. Insert the supporting legs in the openings of the silo spreader provided, and secure them with the associated locking pins. The silo spreader must then be adjusted to a sufficient height by means of the support device.



Achtung

**Observe the height of the platform (approx. 10 cm higher) when adjusting the support device.**

Then drive the vehicle centrally under the spreader. Using the support device, lower the silo spreader onto the floor of the platform vehicle by turning the adjusting handle. The supporting legs are then to be removed. The spreader must be aligned centrally on the platform. Using the supplied fastening equipment, which is matched to each vehicle type, lash the spreader to the platform and secure it, or mount it on the device carrier (see the assembly instructions for the carrier vehicle). The side boards can now be folded up or removed, as required. The disc assembly is then folded downwards out of the transport position, and secured in a fixed position with a locking pin with linchpin. All the important connecting and securing elements must be checked before starting operation of the spreader.

### 3.1.1 Supporting legs

The height-adjustable, stationary supporting device allows the spreader to be mounted on or removed from the carrier vehicle without problems.



**Achtung**

**Use of the supporting device is only permitted when the silo spreader is empty! The useful load of each support device is at most 200 kg.**

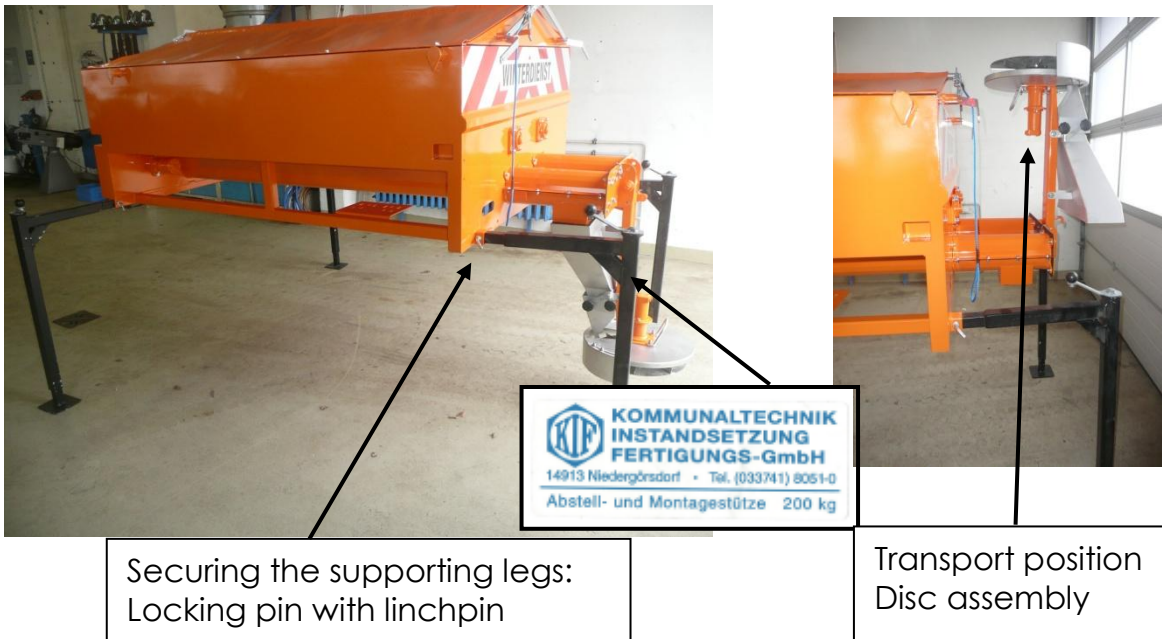

Securing the supporting legs:  
Locking pin with linchpin

Transport position  
Disc assembly

The height-adjustable, mobile supporting device allows the spreader to be mounted on or removed from the carrier vehicle without problems. One swivel castor can be fixed in order to stop the device from rolling away accidentally when it has been put down.



### 3.1.2 Assembly of the silo spreader on base vehicle with skip loader

If the carrier vehicle has a skip loader, the spreader is suspended in the chains and placed onto the vehicle. The spreader must then be aligned such that it is located centrally towards the driver's cab at the attachment points on the vehicle. Using the supplied fastening equipment, which is matched to each vehicle type, lash the spreader to the vehicle and secure it (see the assembly instructions for the carrier vehicle, Section 10).



**Achtung**

**The chains of the skip loader must not be removed from the spreader!**

**Make sure that the chains do not sag!**

It is not possible for the silo spreader to slip if the assembly instructions and safety rules are complied with.

Picking up the silo spreader



Silo spreader in the working position



### 3.2 Disassembling the silo spreader



Achtung

**Disassembling the spreader is only permitted when the spreader container is empty!**  
**Perform the disassembly steps in reverse order to the assembly instructions (see Section 3.1).**

The empty spreader can also be left for a longer period of time on the supporting legs.

### 3.3 Transport position

The disc assembly must be folded up and secured in order to allow transport of the silo spreader. The existing locking pin with linchpin, which is inserted in the upper position, is used for fastening. The hydraulic and electric lines from the carrier vehicle must be removed, and securely hung at the spreader, or fastened if necessary. The chains are inserted into the existing container brackets for transport with a crane.

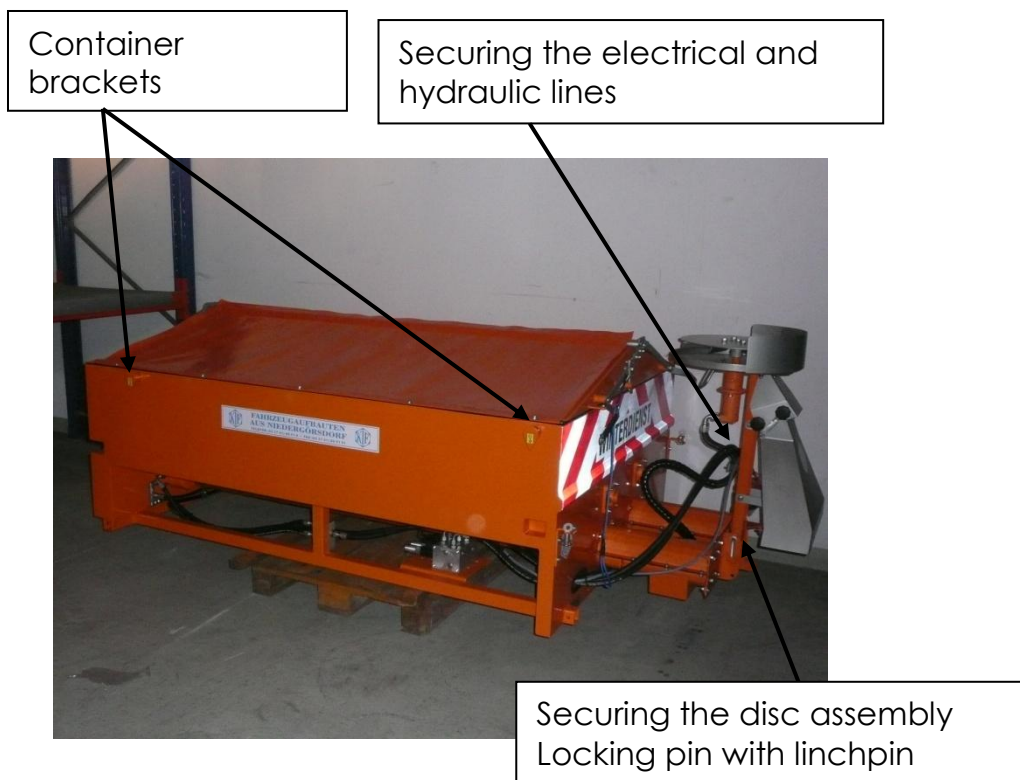

### 3.4 Connection to the on-board hydraulic system of the carrier vehicle

The spreader is supplied with energy via a separately actuated circuit of the on-board hydraulic system of the vehicle (rear hydraulics).



**Observe the identification of the hydraulic lines, and do not mix up the connection sequence, since otherwise damage to the spreader or the equipment is possible.**

#### Connection sequence of the hydraulic lines:



Achtung

**Connect hydraulic line – Return “T”  
Connect hydraulic line – Pressure side “P”**

**Adjust the oil quantity to about 20 – 35 l / min  
(See the user manual for the carrier vehicle)**

**See Point 9 .1 of the hydraulic circuit diagram.**



**The hydraulics must be switched off and depressurised when working on the carrier vehicle; the vehicle must be switched off and the ignition key withdrawn.  
The vehicle must also be secured to stop it from rolling away!**

### 3.5 Start-up

Operation of the spreader can start once the spreader has been mounted on the vehicle and secured. The vehicle-specific controller for the hydraulics must be actuated for this purpose, so that the hydraulic system is switched on. The discharge shaft, and the agitator shaft if present, turn.

A visual check of all the hydraulic lines and hydraulic units must be carried out to ensure safe operation of the spreader. Check for leaks and proper operation. If any malfunctions occur, see the section on "Troubleshooting", or call the technical service at your service workshop.

#### 3.5.1 Adjusting the scatter pattern

The scatter range and the gritting quantity are adjusted by the hand-operated flow valves (hydraulic block) of the spreader.

- **Turn in the open direction → higher speed → wide scatter pattern**
- **Turn in the close direction → lower speed → narrow scatter pattern**



The direction of the scatter pattern is changed by altering the impact point of grit on the spreader plate as follows:

**Up to 06/2015:**

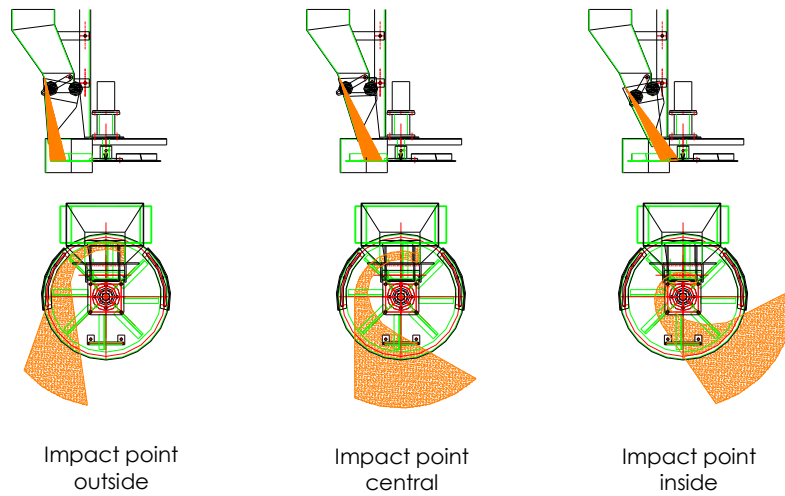

The direction of the scatter pattern is changed by adjusting the guide plate as follows:

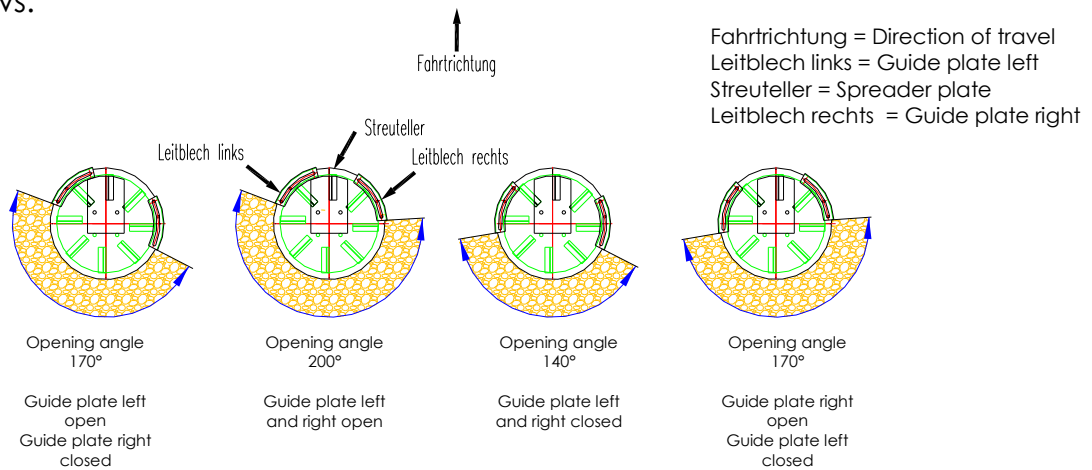

The direction of the scatter pattern is changed by adjusting the disc assembly as follows:

**As from 06/2015**

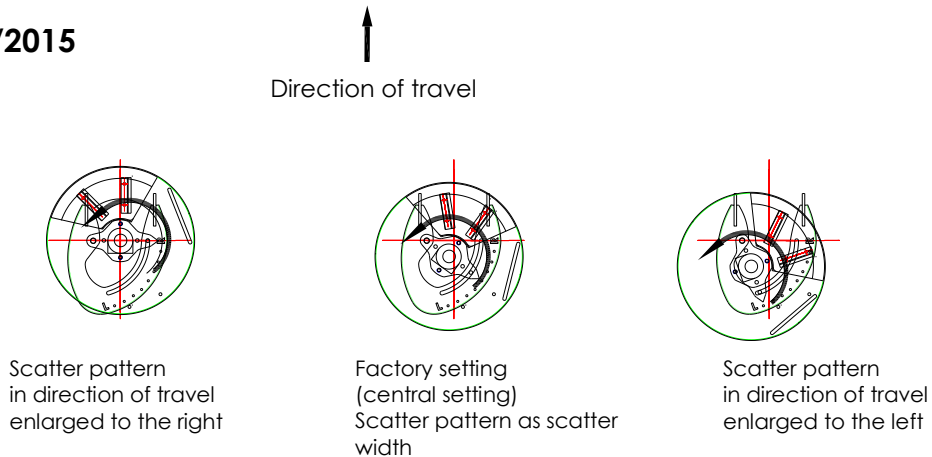

### 3.5.2 Adjusting the gritting quantity

#### Silo spreader and silo spreader/flat

The gritting quantity can be adjusted through the rotation speed of the conveying screw at the manually adjustable flow valve (hydraulic block) of the spreader.

- Turn in the open direction → higher speed → corresponds to more grit
- Turn in the close direction → lower speed → corresponds to less grit



**The grit must always be dry and pourable!**

#### Damp salt silo spreader

The desired gritting quantity is adjusted by the hand-operated flow valve (hydraulic block) of the spreader.

The desired lye quantity is adjusted by the hand-operated flow valve (hydraulic block) of the spreader.

- Basic setting:**
- 1: 0.7 → corresponds to a dry salt proportion of 70%
  - 1: 0.3 → corresponds to a lye proportion of 30%



**The "dry salt" grit must be dry and pourable!**

#### Belt silo spreader

The gritting quantity can be adjusted through the rotation speed of the conveying belt at the manually adjustable flow valve (hydraulic block) of the spreader.

- Turn in the open direction → higher speed → corresponds to more grit
- Turn in the close direction → lower speed → corresponds to less grit

**The slide at the conveyor belt should only be slightly open.**

Basic setting: 3 to 4 times the grain size.

e.g. grit grain size → 2 to 4 mm

2 x 3 = 6 mm

4 x 4 = 16 mm

**The slide should accordingly be between 6 and 16 mm open (see the spreader scale).**

We generally recommend adjusting a smaller opening, so that a greater conveying speed can be achieved, and, with that, a higher delivery quantity.



**The grit must always be dry and pourable!**

### 3.5.3 Path-dependent spread rate regulation

This type of regulation of the gritting quantity is operated from the driver's cab, and ensures a continuous, consistent grit output. Such dosing ensures that same quantity of grit is delivered per square meter, depending on the speed of the carrier vehicle. (See functional description, Section 9.4, page 49)



**The assembly and connection plans are made available by KIF GmbH to authorised service workshops exclusively. If you have any questions or problems, please contact your local service workshop.**

### 3.5.4 Switching off in an emergency

To switch the spreader off in an emergency, the vehicle-specific operating element for the hydraulics must be used, so as to stop operation of the hydraulics. The vehicle must be switched off, and the ignition key withdrawn.

Before operation of the spreader can start again, the reason for the emergency stop must be determined, and must be properly corrected. Only then should the spreader be unlatched again and started up.



**Achtung**

**After an EMERGENCY OFF action, the silo spreader must only be started again when the user has made sure that the reason for the EMERGENCY OFF has been put right properly.**

### 3.5.5 Shutting down

The following points must be observed to shut the silo spreader down:

- Stop all the rotating and moving parts and assemblies by actuating the appropriate, vehicle-specific controller for the hydraulics in the vehicle.
- Actuate the controller for the engine-driven power-take off in order to switch off the drives for the spreader.
- In the case of path-dependent spread rate control, button no. 1 on the operating element should be switched off.

- After shutting down, the spreader should be parked properly and securely on the premises.
- After shutting down, the equipment should be properly and securely parked, and secured to prevent unauthorised use.

**Disassembling the spreader is only permitted when the spreader container is empty!**



**Achtung**

**When disassembling the spreader, the working steps of the assembly instructions should be carried out in the reverse order (see Section 3.1, page 28).**

The empty spreader can also be left for a longer period of time on the supporting device.

### 3.5.6 Filling procedure for the damp salt silo spreader

- The grit container is filled with the dry, pourable grit.



**The grit must always be dry and pourable, ideally with a grain size of 0.5 - 2.0 mm.**

- The lye container/brine tank is filled with lye.

#### **Lye tank filling procedure:**

- Remove the sealing cover at the C-connection of the spreader (caution: the valve must be closed before removing the cover.)
- Connect the filling hose to the C-connection at the filling nozzle of the lye tank.
- Connect the filling hose to the lye reservoir.
- Open the valve at the filling nozzle of the vehicle.
- Finally, open the valve at the lye reservoir; the filling process can start.
- 



**The filling process is to be carried out without the use of pressure. The filling process should be carried out slowly and sensitively. (Regulation through actuating the valve at the lye tank) The construction of the vent must not be changed! The fill level indicators of the two tanks show the filling process.**



**Container filled – stop filling process (close valve). Close the valve at the filling nozzle of the vehicle. Remove the filling hose. Screw on the sealing caps. Close the vent cock 31, 32.**



Warnung

The lye container must not in general be filled with water – FROST HAZARD!!!

If the type of brine is changed, the entire lye system must be thoroughly flushed out and cleaned.

The protection, safety and accident prevention regulations must always be complied with when handling lyes and corrosive agents.

## 4 Faults



### 4.1 Troubleshooting



Achtung

If faults should occur on the spreader, it must be switched off immediately. Rectification of faults must be carried out by trained personnel according to the specifications of the manufacturer. It is essential that the spreader is inspected before starting up again. Troubleshooting help may be found in the "Troubleshooting" section, or at your local service workshop.

Repair and service work on the spreader may only be carried out after the hydraulic system and the vehicle have been switched off.

Fault	Cause	Rectification
<b>Machine won't start up</b>	Controller not switched on	Switch on the lever for engine-driven power-take off Switch on the vehicle-specific operating element (main switch for hydraulics).
	Chain broken	Replace chain and retension
	Foreign object has got stuck	Remove foreign object and check for damage
	Actuate the lever for engine-driven power-take off Main switch for hydraulics not actuated	Check the lever and the switch, and rectify the reason for the EMERGENCY OFF
	Machine not switched on	Press the "ON" button
<b>Irregular scatter pattern</b>	Foreign object in the spreader container	Remove foreign object



## 4.2 Troubleshooting the hydraulics

Fault	Effect	Rectification
<p><b>Faulty hydraulic hose: to the on-board hydraulic system</b></p> <p><b>Faulty pipe To the hydraulic motor / spreader disc</b></p>	<p>Spreader has no function</p> <p>No oil to the hydraulic motor</p> <p>No grit delivery</p>	<p>Change hydraulic hose</p> <p>Replace pipe</p> <p>Replace hydraulic hose</p>
<p><b>Flow regulation block has no function</b></p>	<p>Electronics failed</p>	<p>On-the-spot measure: Remove protective cap, start the spreader by hand. Repair or replace electronics</p>
<p><b>Hydraulic motor has no function</b></p>	<p>No grit delivery</p>	<p>Check the oil pressure, check the hydraulic motor, replace if necessary.</p>

Caution: Only original parts that have been approved by the manufacturer are permitted for the replacement of assemblies and components.



Achtung

**Hydraulic oils are a hazard to the environment and must not be released to the ground. If hydraulic oil escapes, it must be trapped, or must be absorbed or neutralised with granulate. If oil has already got into the ground, the ground must be cleared away, put into an oil-tight container, and taken away for environmentally appropriate disposal. It may be necessary to inform the responsible authorities (fire service and police).**

## 5 Care and inspection of the gritter

Residual matter must be removed from spreader every day after spreading has finished. This is done by means of rinsing using a gentle non-pressurised water jet. Note the following:



Warnung

**The machine must be switched off before starting to clean it!**  
**No high-pressure cleaning is to be used.**  
**The connecting points and fastening elements must be re-waxed after cleaning to reduce the risk of rusting.**

Following the inspection plan provided by the manufacturer, the silo spreader must be inspected regularly at predefined time and operating intervals, and the appropriate predefined inspection and servicing work must be carried out. If faults or deviations are found, the operator must contact the nearest service workshop or the manufacturer in order to have any necessary repairs carried out.

Inspection plan	
<b>Daily inspection</b>	A visual and functional check of the whole of the equipment must be performed every time work starts.
<b>Monthly inspection</b>	The whole of the equipment must be examined for damage through visual and functional checks. All lubrication points are to be lubricated according to the lubrication plan. All connecting elements are to be checked for firm seating.
<b>Post-season</b>	Basic equipment cleaning The whole of the equipment must be examined for damage and faults through visual and functional checks. All the lubrication points and drive chains are to be treated with a lubricating grease. All connecting elements are to be checked for firm seating. All the bearing locations of the shafts are to be subjected to a visual and functional check. Touching-up paint

Only the grease approved by the manufacturer is to be used! (See Section 7, page 41, Approved operational and auxiliary materials).

**See annex: Lubrication plan**





## 6 Maintenance and servicing

For questions concerning maintenance and servicing, our *Service Team* will be pleased to be available to you in person or on the telephone. We will also happily help you to find the right service workshop, or a dealer in your area.

### 6.1 Mechanical maintenance

Defective parts of the spreader must either be repaired immediately or replaced with new original parts.

When replacing defective parts, use only original replacement parts from the manufacturer.

Where damage is caused by the use of non-original replacement parts or accessories, any liability and warranty on the part of the manufacturer, KIF GmbH, is excluded. The manufacturer's guarantee and goodwill is also excluded.



Warnung

- **The mechanical maintenance of the spreader may only be carried out by qualified and authorised specialist personnel.**
- **The engine of the vehicle must be switched off during any work.**
- **When maintenance is complete, all the safety equipment and attachments must be refitted properly and correctly.**

Special protection and precautionary measures are needed when welding work needs to be done on the spreader, since the pivoting bearing parts or the electrical system could be damaged.

Consultation with the manufacturer, KIF GmbH, should therefore always take place before any welding work.

The local regulations for safety and accident prevention during maintenance and welding work must be complied with.

### 6.2 Hydraulic maintenance

Defective hydraulic parts of the gritter must either be repaired immediately or replaced with new original parts.

When replacing defective parts, only use original replacement parts from the manufacturer.

Where damage is caused by the use of non-original replacement parts or accessories, any liability and warranty on the part of the manufacturer, KIF GmbH, is excluded. The manufacturer's guarantee and goodwill is also excluded.



Warnung

- **The hydraulic maintenance of the spreader may only be carried out by qualified and authorised specialist personnel.**



- The hydraulic system must always be switched off and depressurised when working on the chain drive.
- The vehicle must be switched off, and the ignition key withdrawn.

The local regulations for safety and accident prevention during maintenance and repair work must be complied with.



Achtung

Hydraulic oils are a hazard to the environment and must not be released to the ground. If hydraulic oil escapes, it must be trapped, or must be absorbed or neutralised with granulate. If oil has already got into the ground, the ground must be cleared away, put into an oil-tight container, and taken away for environmentally appropriate disposal. It may be necessary to inform the responsible authorities (fire service and police).

## 7 Suitable operating materials and auxiliary materials

Only approved operating materials and auxiliary materials may be used with the spreader to ensure that the system functions optimally.

If other operating and auxiliary materials, not approved by the manufacturer, are used, and damage to the spreader or vehicle occurs as a result, any warranty and guarantee on the part of the manufacturer, KIF GmbH, is completely excluded.

### Approved hydraulic oil: Hydraulic oil HVLP-46



Density DIN 51757 15 °C 880 kg/m<sup>3</sup>.  
 Viscosity DIN 51562 40 °C 46 mm<sup>2</sup>/s  
 Viscosity DIN51562 100 °C 8 mm<sup>2</sup>/s

**Approved lubricant:** Lubricant EP-multipurpose grease MZP 2

**Operating temperature range:** -30° to +130°

**Approved preserving agent:** Cavity Wax Transparent

**Cleaning agents:** Anti-Stone anti-calcification agent;  
 Aut-ShamTWO

Cleaning agents used must not be flammable, corrosive or toxic. Use only environmentally friendly and non-hazardous cleaning agents. The cleaning agent is chosen depending on the item to be cleaned and the level of contamination.



## 8 Disposing of the equipment

After it has reached the end of its service life, the equipment must be properly and correctly disposed of using the most up-to-date methods available. Contact a company specialised in disposal if necessary.

9 Technical documents

9.1 Hydraulic circuit diagram

9.1.1 Silo spreader / belt silo spreader with manual adjustment

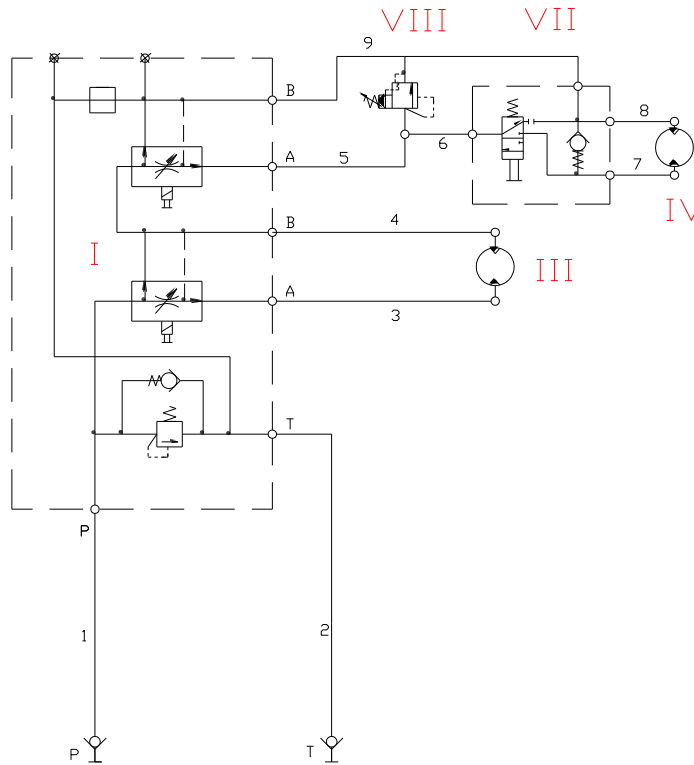

Hose list:

No.	Designation	Per. max. press.	Description
1	HD hose CM 05	350 bar	<b>Carrier vehicle - Control block</b>
2	HD hose CM 06	350 bar	
3	HD hose CM 05	350 bar	<b>Motor - Control block</b>
4	HD hose CM 05	350 bar	<b>Control block – Pressure limit</b>
5	HD hose CM 05	350 bar	
6	HD hose CM 05	350 bar	<b>Pressure limit - Disc stop</b>
7	HD hose CM 05	350 bar	<b>Disc stop - Disc motor</b>
8	HD hose CM 05	350 bar	
9	HD hose CM 05	350 bar	<b>Disc stop - Control block</b>

### 9.1.2 Silo spreader / belt silo spreader with path-dependent spread rate control

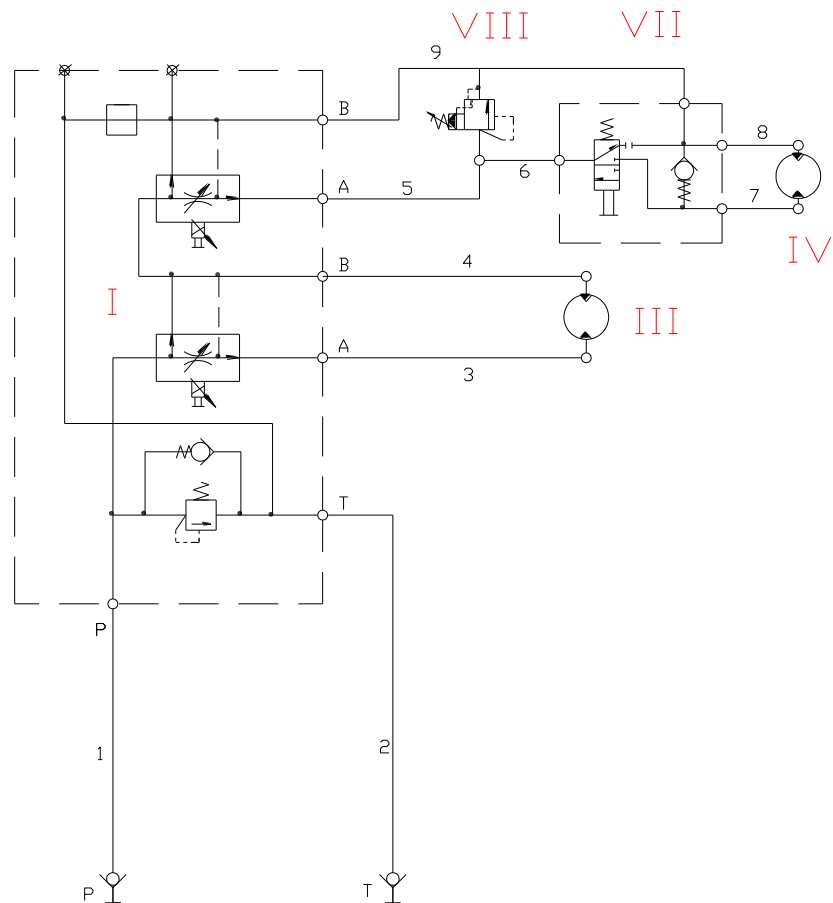

Hose list:

No.	Designation	Per. max. press.	Description
1	HD hose CM 05	350 bar	<b>Carrier vehicle - Control block</b>
2	HD hose CM 06	350 bar	
3	HD hose CM 05	350 bar	<b>Motor - Control block</b>
4	HD hose CM 05	350 bar	
5	HD hose CM 05	350 bar	<b>Control block – Pressure limit</b>
6	HD hose CM 05	350 bar	<b>Pressure limit - Disc stop</b>
7	HD hose CM 05	350 bar	<b>Disc stop - Disc motor</b>
8	HD hose CM 05	350 bar	
9	HD hose CM 05	350 bar	<b>Disc stop - Control block</b>

### 9.1.3 Silo spreader / flat (1 chamber) with manual adjustment

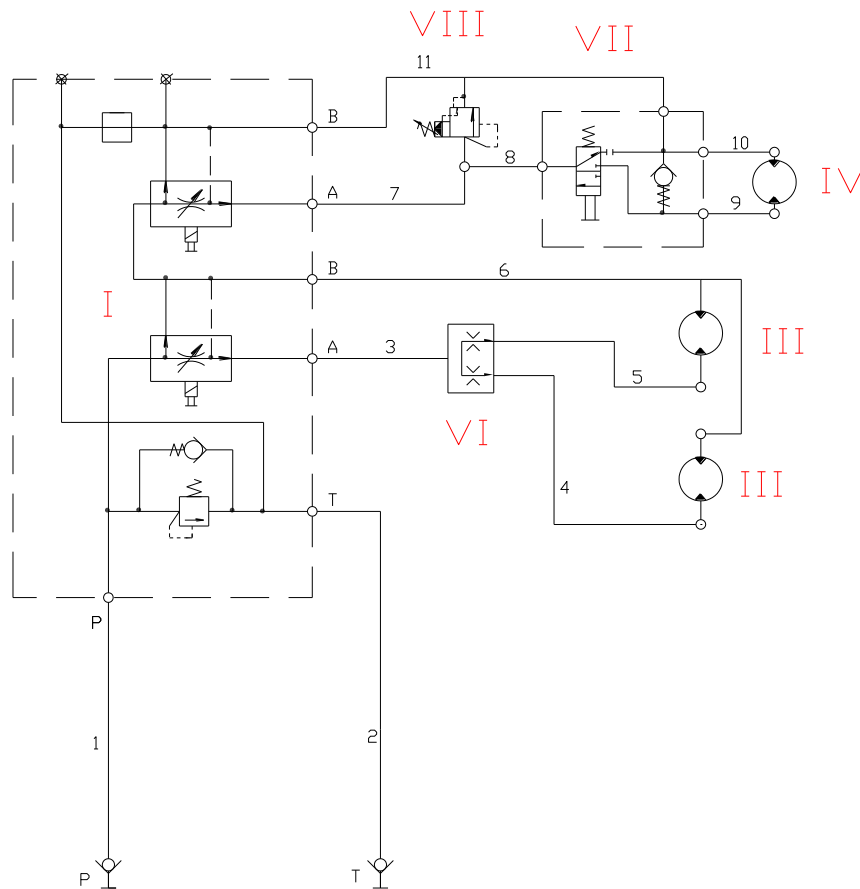

Hose list:

No.	Designation	Per. max. press.	Description
1	HD hose CM 05	350 bar	<b>Carrier vehicle - Control block</b>
2	HD hose CM 06	350 bar	
3	HD hose CM 05	350 bar	<b>Quantity divider - Control block</b>
4	HD hose CM 05	350 bar	<b>Quantity divider - Motor</b>
5	HD hose CM 05	350 bar	
6	HD hose CM 05	350 bar	<b>Motor - Control block</b>
7	HD hose CM 05	350 bar	<b>Control block - pressure limit</b>
8	HD hose CM 05	350 bar	<b>Pressure limit - Disc stop</b>
9	HD hose CM 05	350 bar	<b>Disc stop - Disc motor</b>
10	HD hose CM 05	350 bar	
11	HD hose CM 05	350 bar	<b>Disc stop - Control block</b>

### 9.1.4 Silo spreader / flat (1 chamber) with path-dependent spread rate control

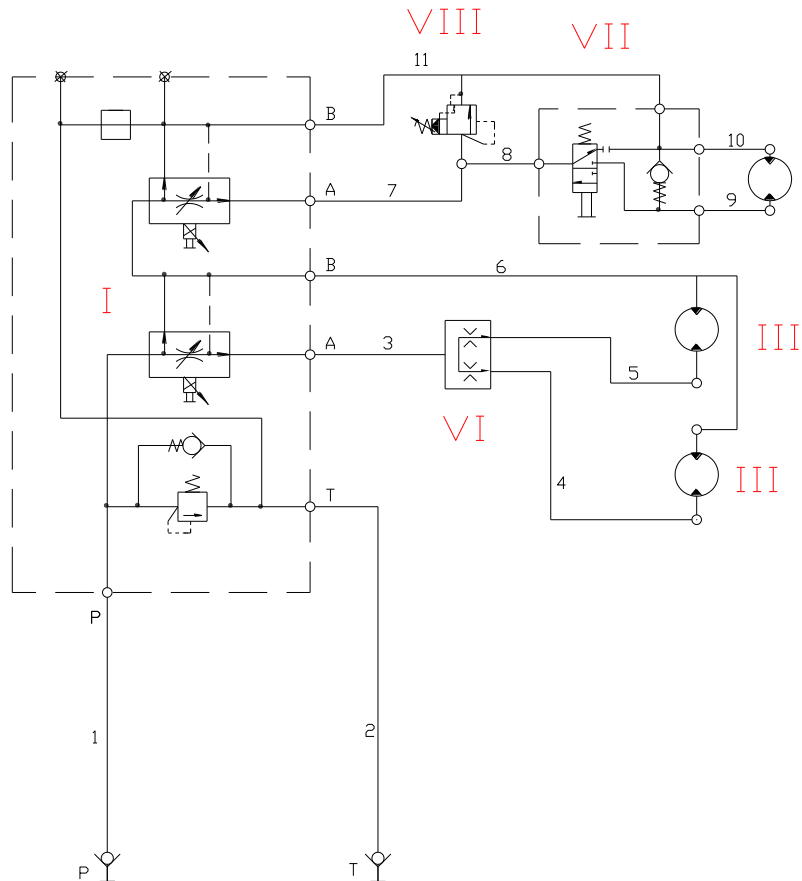

Hose list:

No.	Designation	Per. max. press.	Description
1	HD hose CM 05	350 bar	<b>Carrier vehicle - Control block</b>
2	HD hose CM 06	350 bar	
3	HD hose CM 05	350 bar	<b>Quantity divider - Control block</b>
4	HD hose CM 05	350 bar	<b>Quantity divider - Motor</b>
5	HD hose CM 05	350 bar	
6	HD hose CM 05	350 bar	<b>Motor - Control block</b>
7	HD hose CM 05	350 bar	<b>Control block - pressure limit</b>
8	HD hose CM 05	350 bar	<b>Pressure limit - Disc stop</b>
9	HD hose CM 05	350 bar	<b>Disc stop - Disc motor</b>
10	HD hose CM 05	350 bar	
11	HD hose CM 05	350 bar	<b>Disc stop - Control block</b>

### 9.1.5 Silo spreader / flat (2 chamber) / damp salt silo spreader with path-dependent spread rate control

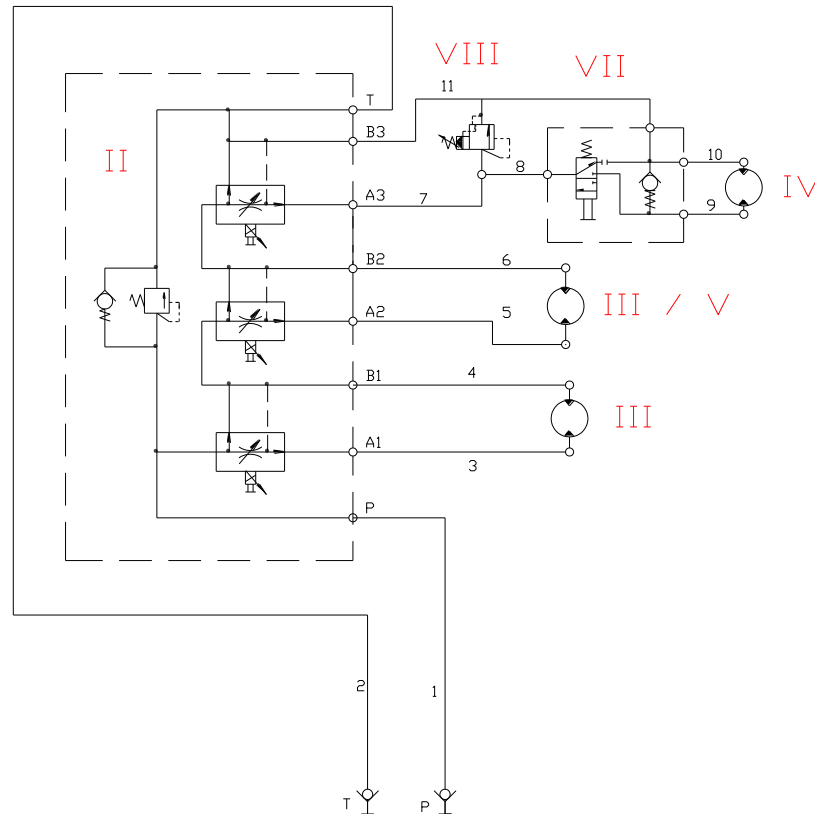





Hose list:

No.	Designation	Per. max. press.	Description
1	HD hose CM 05	350 bar	<b>Carrier vehicle - Control block</b>
2	HD hose CM 06	350 bar	
3	HD hose CM 05	350 bar	<b>Motor (lye pump) - Control block</b>
4	HD hose CM 05	350 bar	
5	HD hose CM 05	350 bar	
6	HD hose CM 05	350 bar	
7	HD hose CM 05	350 bar	<b>Control block - pressure limit</b>
8	HD hose CM 05	350 bar	<b>Pressure limit - Disc stop</b>
9	HD hose CM 05	350 bar	<b>Disc stop - Disc motor</b>
10	HD hose CM 05	350 bar	
11	HD hose CM 05	350 bar	<b>Disc stop - Control block</b>

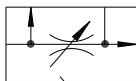
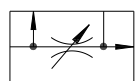

9.1.6 Device list hydraulic silo spreader / belt silo spreader / damp salt silo spreader manual adjustment / path-dependent spread rate control

No.	Qty.	Designation	Description	Per. max. pressure	Symbol	Comment
I	1	Control block	STB SRCA 2-fold	250 bar	 Path-dependent	
	1	Control block	2-fold flow controller	250 bar		
II	1	Control block	STB SRCA 3-fold	250 bar	 Manual adjustment	
	1	Control block	3-fold flow controller	250 bar		
III	1	Motor chain drive	OMM 315	225 bar		
	1	Motor conveyor belt	OMM 400	225 bar		
IV	1	Motor disc unit	OMM 12.5	225 bar		
V	1	Lye pump with hydraulic motor	Membrane pump Kappa 15 with EPMM 50	225 bar		
VI	1	Quantity divider	Sun valve MMV	350 bar		
VII	1	Disc stop	THH-970096	350 bar		
VIII	1	Pressure limiting valve with slider	Sun valve RQEB	350 bar		

## 9.4 Functional description of the control unit

### 9.4.1 Digital controller ELMR 152 - 42 / 1, 2, 3-fold control

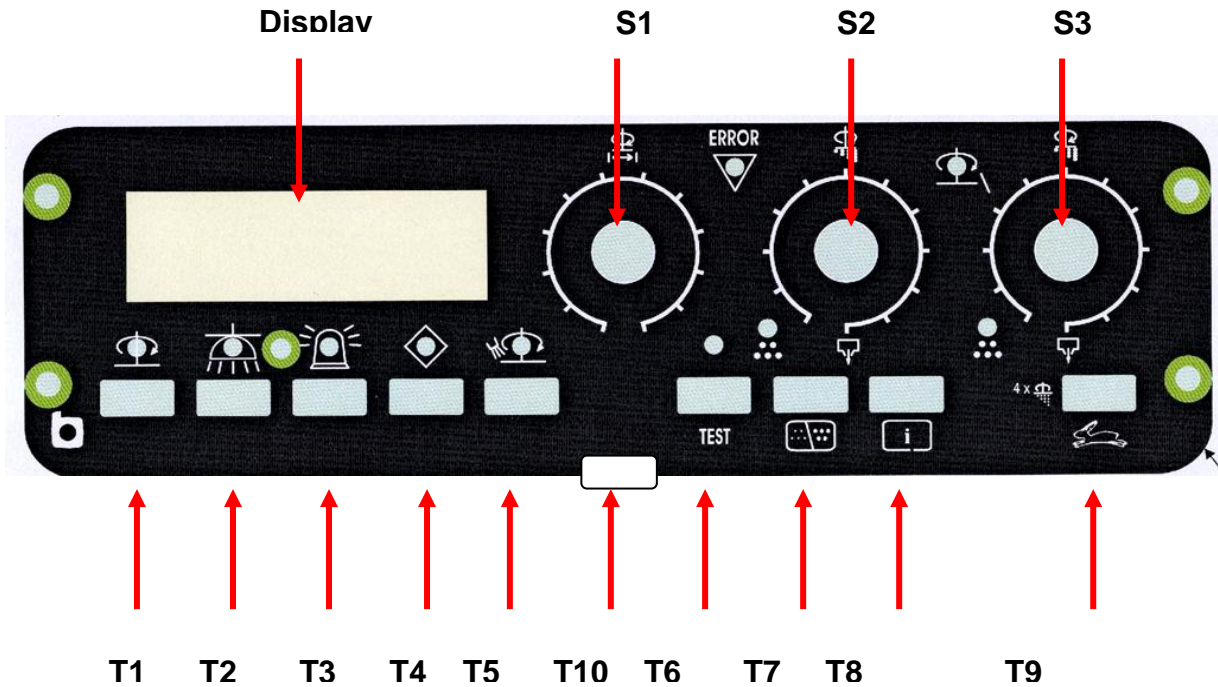

Button	Normal operation
T1	On/Off
T2	Working lights
T3	Rotating beacon
T4	Switchover button for multi-functional rear-mounted spreader
T5	Damp salt ON/OFF
T6	Gritting at standstill → 20 km/h
T7	Switchover between salt – chippings – sand
T8	Info button
T9	Danger button
T10	Gritting On / Off
Switch	Function
S1	Scatter range
S2	Delivery I
S3	Delivery II

## 9.4.2 CAN BUS control module (as at 12/2013)

### 9.4.2.1 Structure of the controller

The controller consists of the following components:

- Controller IMPact-02
- Cable harness IMPact-02
- Cable harness, cabin
- Operating device HHI-10
- RAM bracket with screw stand
- Optional suction foot

An overview illustration of the wiring can be found under Section "10 Technical documents for carrier vehicle" in this user manual. The controller is supplied programmed, and ready for connection. The controller can operate the disc spreader, roller spreader, damp salt and multi-function devices. The type of spreading to be operated in each case is enabled in the parameters (see the parameterisation of the spreader).

### Operating device HHI-10



## Controller IMPact-02

Versorgung und CAN-Bus  
5polige M12 Buchse  
Anschluss von X2



Ein/Ausgänge  
42poliger Steckverbinder  
mit Rastung und Dichtung  
Anschluss von X1

M8 Buchse PG-Funktion  
für interne Aufgaben

**Maximale Belastung der Ausgänge:**  
Summenstrom: 18A  
4 x Proportionalventilansgänge: je 3,0A  
Rundumleuchte: 3A  
Arbeitscheinwerfer: 3A

Versorgung und CAN Bus = Power supply and CAN bus  
5polige M12 Buchse = 5-pin M12 socket  
Anschluss von X2 = Connection for X2

Ein/Ausgänge 42poliger = Inputs/outputs  
Steckverbinder mit = 42-pin plug connector with  
Rastung und Dichtung = latching and seal  
Anschluss von X1 = Connection for X1

M8 Buchse PG-Funktion = M8 socket PG function for  
für interne Aufgaben = internal purposes

## Cable harness IMPact-02

X3  
2polige AMP Buchse  
X4  
3polige AMP Buchse  
X5  
3polige AMP Buchse  
X2  
M12 5poliger Stecker  
X6  
9 poliger Stecker



2.a  
Verstärker Körperschall-  
mikrofon  
vergossen

X1  
42polige Buchse  
mit Rastung

2polige AMP Buchse = 2-pin AMP socket  
3polige AMP Buchse = 3-pin AMP socket  
M12 5poliger Stecker = M12 5-pin plug  
9poliger Stecker = 9-pin plug  
Verstärker Körperschall-  
mikrofon geschlossen = Reinforced, cast,  
structure born  
sound  
microphone  
42polige Buchse mit  
Rastung = 42 pin socket with  
latching



Montiertes IMPact-02 = Assembled IMPact-02

## Cable harness, cabin

9polige Buchse mit  
Rastung und Dichtung = 9 pin socket with  
Flanschmutter für = latching and seal  
Wandeinbau = Flange nut for wall  
M12 5poliger Stecker = 5 pin plug  
Montierte Verbindung = Assembled  
X6-X10 = connection X6-X10  
Flansch für = Flange for wall  
Wandmontage = mounting  
Schutzkappen: = Protective caps:  
Vor dem Verschrauben = Remove before  
der Verbindung = screwing the  
entfernen, danach die = connection  
Kappen miteinander = together, then  
verschrauben = screw the caps  
together



X10  
9polige Buchse  
mit Rastung und Dichtung  
Flanschmutter für Wandeinbau

X11  
M12 5poliger Stecker

montierte Verbindung X6-X10



Flansch für Wandmontage

Schutzkappen:  
Vor dem Verschrauben der Verbindung entfernen  
danach die Kappen miteinander verschrauben !

## Light sensor

The integrated light sensor detects the brightness of the surroundings. The background lighting of the display is switched between day and night modes with the aid of the sensor. The brightness threshold and changeover time can be adjusted.

### 9.4.2.2 Spreading

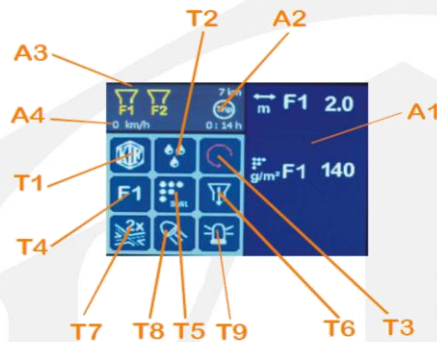

#### Item: A1 and A4 - spreader type

The display areas for A1 and A4 show the spreader and the scatter range and gritting quantity adjustment for the different types of spreader.

Preselection through button T1 (select spreader).

- F1 - width: in 0.5 m steps (adjustable limits)
- F1 – quantity: in 5 g steps (adjustable limits) →with salt  
in 10g steps (adjustable limit) →with chippings
- F2 – quantity: in 5 g steps (adjustable limits) →with salt  
in 10g steps (adjustable limit) →with chippings

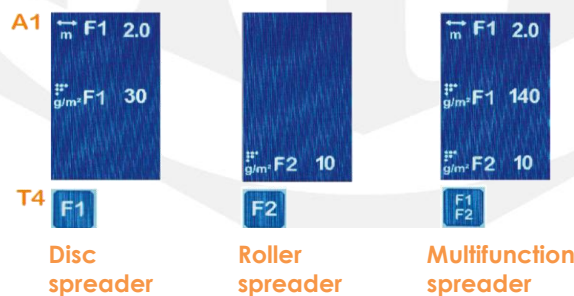

#### Item: A2

The A2 display shows the gritted kilometres and operating hours. The counting starts as soon as the spreader is switched on with button T3. The display can be switched between Trip (day or order values) or Total in the on-board computer menu (button T1). Refer to the on-board computer on page 55 for the switchover and other functions.

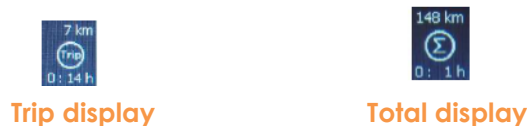

### Item: A3

The A3 display shows the filling level empty in containers F1 and F2, or the absence of grit in F1 (structure-borne sound sensor). The structure-borne sound signal is only displayed when the container F1 is **not empty**, and the signal from the structure-borne sound sensor (no grit at the disk) is absent. It is at the same place as the F1 empty display. An acoustic signal is given if a fault is detected. The signal is repeated at intervals, so that the driver is reminded of the fault. Neither independently switching off, nor other reactions to the fault, occur.

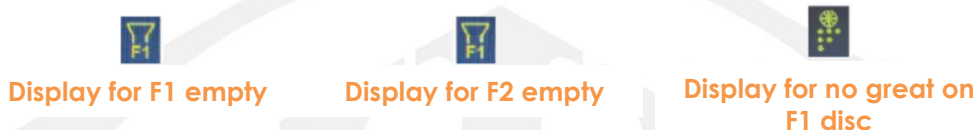

### Item: A4

The display A4 shows the speed, which is determined from the path signal. The parameters must be set in accordance with the base vehicle.

### Item: T1 On-board computer

The menu is changed from, e.g., gritting control to the on-board computer with the T1 button. The spreading functions that are active continue in the background

### Item: T2 Damp salt

If the damp sort function is enabled and the setting, the T2 symbol: **Damp salt activated** appears on the display.

The damp salt function can be switched on by pressing button T2. The **Damp salt switched on** symbol appears.. The damp salt can only be switched on if **Spreading material salt** has been selected using the T5 button, and with the previously correctly selected spreader, with the function F1 or F1 and F2. If, with damp salt switched on, the spreading material or the spreader is switched over to a function that cannot be activated for damp salt, the damp salt function is switched off. The spreader and the spreading material must be reset in order to activate the damp salt function again.



The concentration of the brine can be set in the parameterisation. With this set value, the quantity F1 is reduced when the damp salt function is switched on, and is supplied to the disk again with the appropriate quantity of damp salt.

### Item: T3 - Spreader ON

The spreader is switched on by actuating this button T3. The disc always has a minimum speed of rotation, even when the spreader is switched off. If test operation is switched on in the on-board computer, the Test operation symbol appears. The test operation, and normal operation, can be switched off again by pressing the button again. Refer to page 54 under the on-board computer for the activation of test operation.

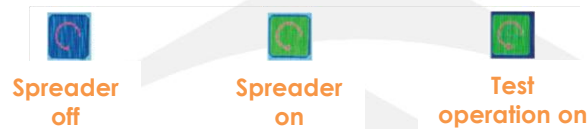

### Item: T4 Selection of the output type (disc/roller)

The type of spreading material output is selected with the T4 button.

### Item: T5 - Selection of the spreading material

The spreading material is selected with the T5 button. The spreading material can no longer be changed when the spreader is switched on.



### Item: T6 - Emptying

Emptying the spreader is switched on with the T6 button. The button only reacts when the spreader is switched off. The function is only switched on if the button is held down for about 5 seconds. Pressing again switches the function off. The F1 and F2 chambers and the damp salt are emptied. The emptying speed is adjustable.



### Item: T7 - Danger gritting

If the spreader is switched on, pressing the T7 button switches on danger gritting (for particularly dangerous regions). Double the quantity of salt is delivered. Pressing the button again switches this function off once more.



**Item: T8 - Working lights**

The working lights at the spreader disc are switched on by pressing the T8 button. Pressing the button again switches this function off once more.



**Item: T9 - Rotating beacon**

The rotating beacon light on the vehicle is switched on by pressing the T9 button, while pressing the button again switches this function off once more.



**On-board computer**

The on-board computer determines the operating hours and the kilometres travelled. This is done separately for daily or project-related evaluation, which can be indicated using the T14 Trip button. The total values are captured their and the totals of all the hours and kilometres are displayed.

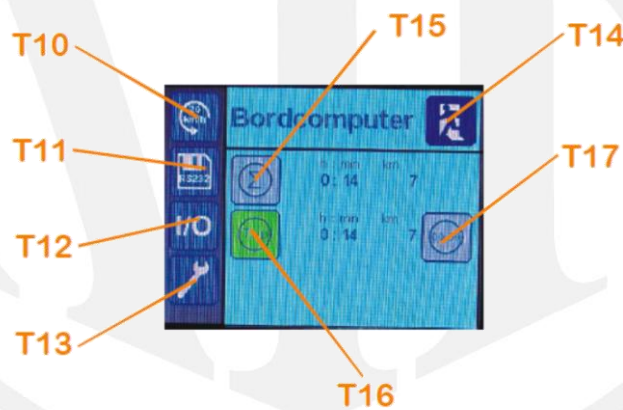

Test operation is switched on by actuating the T3 button. The spreader ignores the speed signal, and operates with the fixed, specified speed of 20 km/h. The associated pulse value is adjustable (see Parameterisation). The symbol lights up green after test operation has been activated. The test operation symbol also appears when returning to the on-board computer. Test operation can be switched off again, either in spreading operation or in the on-board computer, by pressing the T3 button again.





**Item: T11 - Data transfer**

Data transfer is activated by pressing the T11 button. This is not implemented (built in).

**Item: T12 - Input/output monitoring**

Pressing the T12 button switches into the Input/Output function menu. The current states of the inputs and outputs can be queried here.

**Item: T13 - Parameters**

When the T13 button is actuated, the Parameterisation (setting) function menu is switched on. The settings for controlling the spreader can be changed here. This function is only enabled for authorised and trained personnel.

**Item: T14 - Back**

Pressing the T14 button returns to the Spreading Operation function menu.

**Item: T15/T16 - Trip/Total changeover**

The Total value pair is specified for display in spreading operation by pressing button T15. The symbol for button T16 goes off at the same time (changeover). The Trip value pair is specified for display in spreading operation by pressing button T16. The symbol for button T15 goes off at the same time (the display changes over to T16).



**Item: T17 - Reset Trip**

The values for Trip are reset to the value zero by pressing button T17. In order to avoid mistaken operation, it is necessary to hold the button down for about 5 seconds before the values are reset.

**Inputs/Outputs**

The current values of the inputs and outputs are displayed during spreading operation in this function. Settings or activations can be checked here. Values that are necessary for later adjustment of the spreading operation can also be read here.

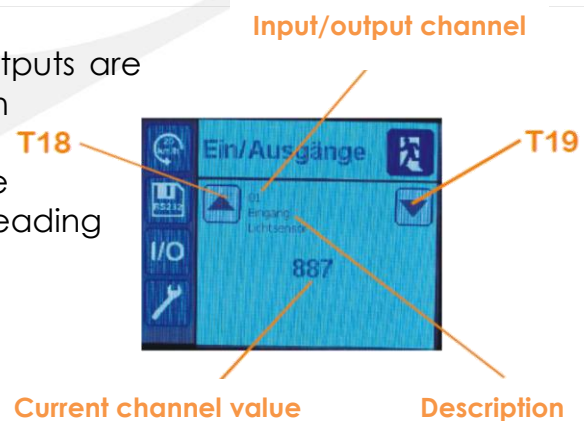

**Item: T18/T19 - Channel selection**

The current inputs and outputs can be selected and displayed by pressing the buttons T18 and T19.

The values of the selected input/output channel can be changed with buttons T18 and T19.

**9.4.3 Functional description of the start-stop mechanism**

**"Start-stop"**

**Silo spreader**

Device – on/off

Disc assembly  
Adjusting the scatter range  
0.5 – 4 m (scale value)

Delivery 1 (1 chamber)  
Adjusting the gritting  
quantity

Delivery 2 (2 chamber)  
Adjusting the gritting  
quantity



Changeover switch

1-chamber spreader  
(spreading width + F1 →  
diodes lit)

2-chamber spreader  
(spreading width + F1 + F2  
→  
diodes lit)

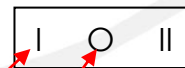

## 9.5 Electric circuit diagram

### 9.5.1 Digital controller 1 / 2 / 3-fold control

Stromversorgung Kabel 5x1:  
 - Anklemmen an die 3pol. Steckdose  
 (Kabel durch die Mittelkonsole führen)

- Plus = Positive
- Masse = Ground
- Input C3 = Pulse C3
- Stecker = Control device plug
- Steuergerät = Control device plug
- Kabel 8x1,5 = Cable 8x1,5
- Steckdose montiert = Assemble socket mounted
- Tremo - hinter Beifahrersitz = Tremo - behind passenger seat
- FUMO - Fußraum Mittelkonsole = FUMO - central bracket footwell

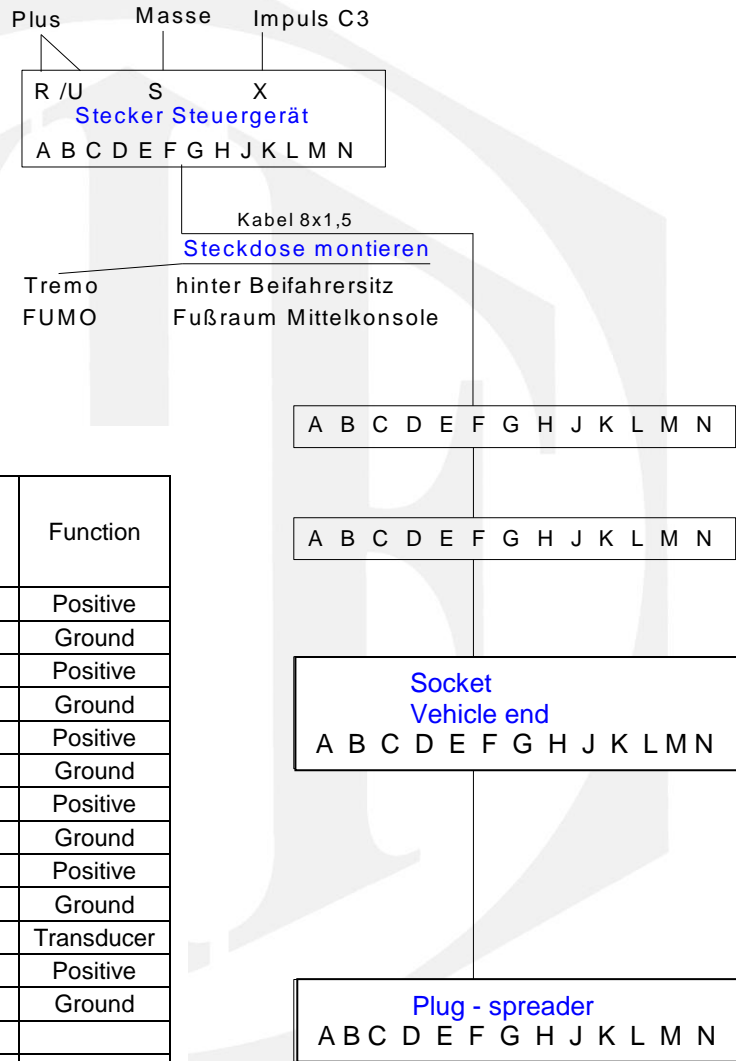

PIN Socket Plug	Cable no.	Identifier	Function
A	1	Disc	Positive
B	2		Ground
C	3	Conveyor 1	Positive
D	4		Ground
E	5	Conveyor 2	Positive
F	6		Ground
G	7	ASW	Positive
H			Ground
J	8	RKL	Positive
K			Ground
L	9	Sensor	Transducer
M	10	Filling level	Positive
N			Ground
R	1, 2	Positive	
S	3, 4	Ground	
U	Bridge from 1, 2	Positive	
X	Green, yellow	C3	

- Magnet Teller = Magnet disc A/B
- Magnet = Magnet
- Förderung 1 Magnet = Magnet conveying 1 C/D
- Förderung 2 Magnet = Magnet conveying 2 E/F
- falls vorhanden = If present

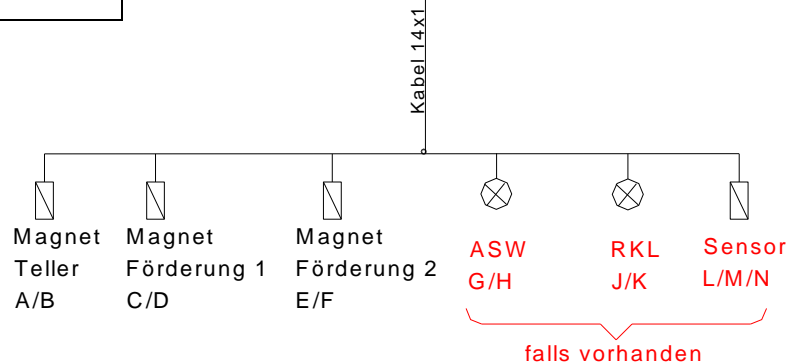

## 9.6 Lubrication plan

### 9.6.1 Silo spreader, damp salt silo spreader

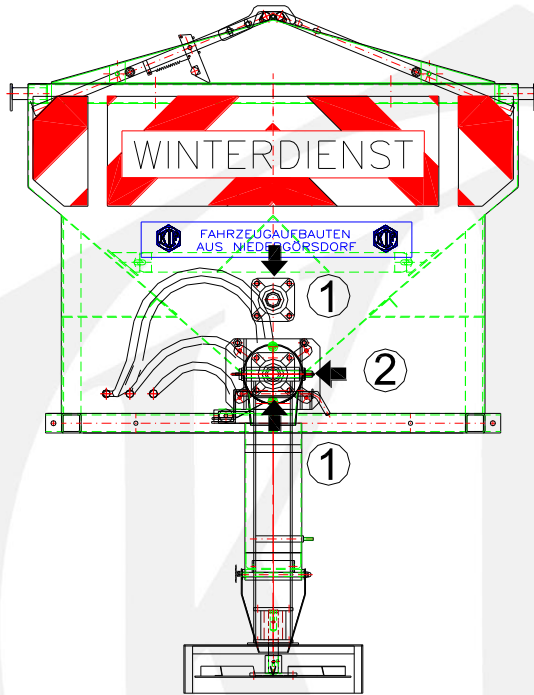

Disc assembly as from  
06/2015

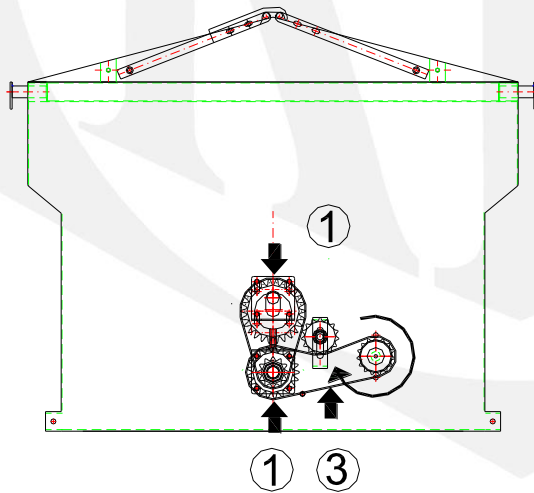
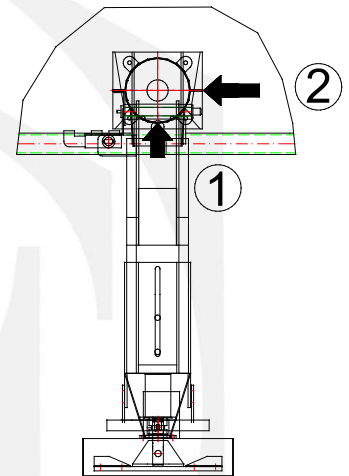

- ① Lubrication head bearing
- ② Lubrication head - spring bolt
- ③ Chain

9.6.2 Silo spreader / flat, damp salt silo spreader

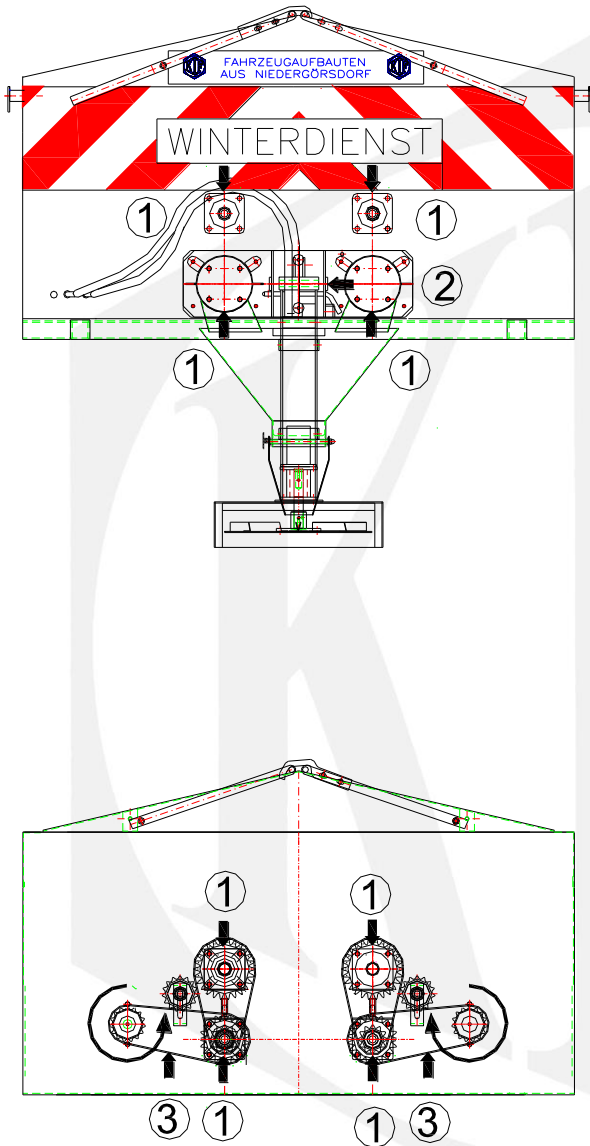

Disc assembly as from

01/2017

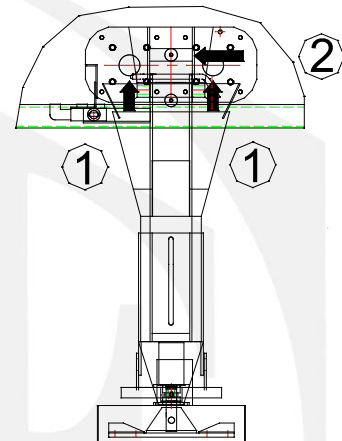

- ① Lubrication head bearing
- ② Lubrication head - spring bolt
- ③ Chain

### 9.6.3 Belt silo spreader

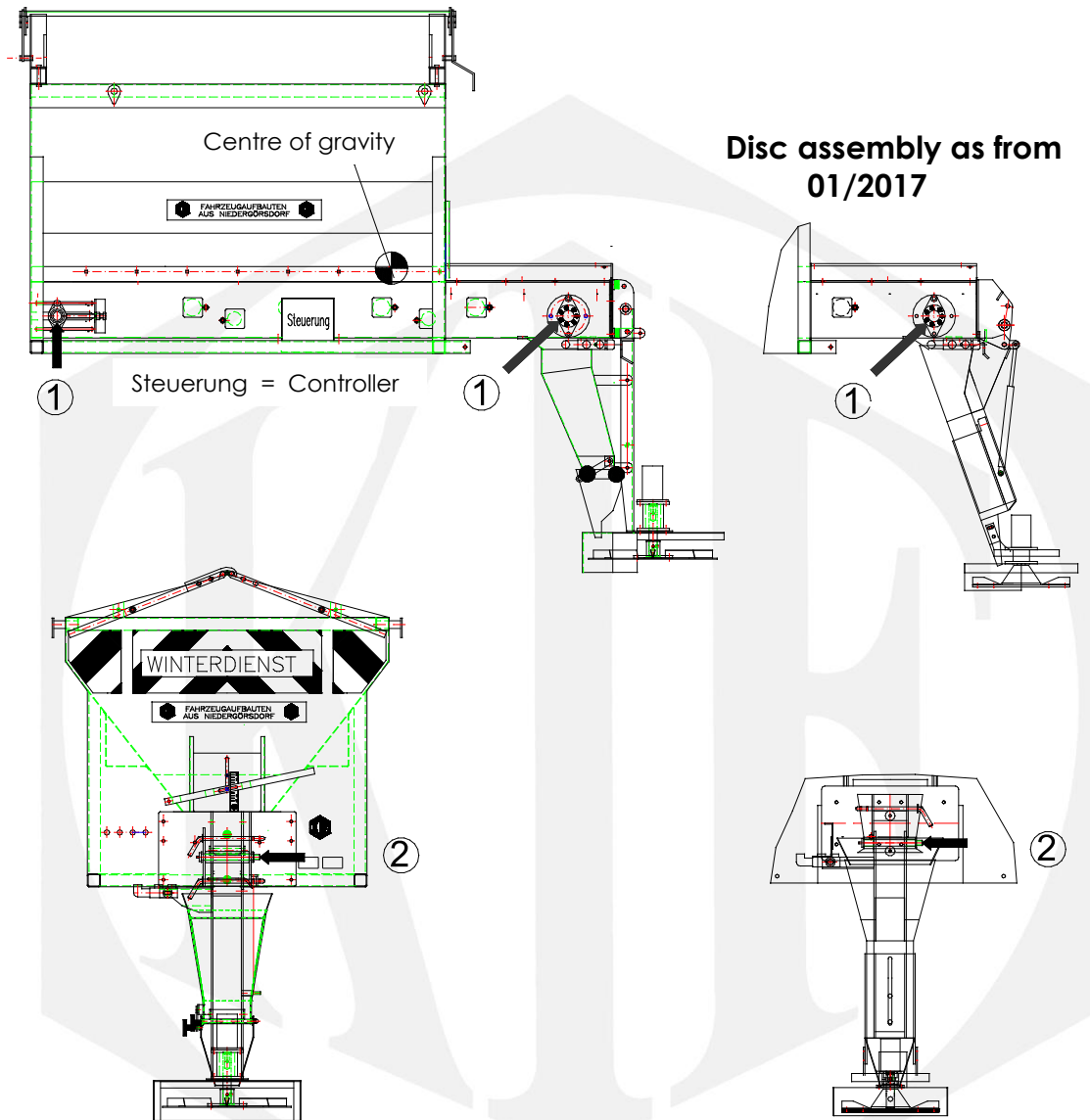

- ① Lubrication head bearing
- ② Lubrication head - spring bolt

## 9.7 Description of the lye pump – Kappa 15 with hydraulic drive

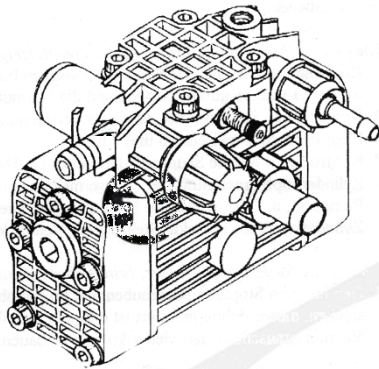

### Technical data:

Delivery capacity: (Q):	15 l/min
Pressure:	20 bar
Speed:	1400 1/min
Engine power:	0.59 kW
Suction connection:	20 mm
Pressure connection:	8 mm
Bypass:	15 mm
Oil quantity:	0.15 kg
Oil type:	SAE 30W40
Weight:	8.5 kg

### Description:

The Kappa – 15 pump has special rubber membranes. The internal mechanical parts operate entirely inside an oil bath. These features guarantee high performance and a long service life. The material of the pump is special anodised aluminium, while those parts that come into contact with the fluid are made of plastic.

### Instructions for use:

The following must be checked before starting pump operation:



- check the level of oil at the oil filling plug,
- check that a filter is fitted to the suction line, and whether it needs cleaning,
- check the air pressure in the pressure reservoir to see that when the pump is stationary the value is always between 7 and 5 bar,
- check that the connection between the pump and the drive and all the hose lines are tight.
- Switch on the pump and adjust the pressure with the control wheel.

### Maintenance:

Shutting the pump down:

Flush the pump through for a few minutes with clear water.

Flush the pump out as described above at the end of the season. Drain the remaining water from the lines and the cylinder heads as follows. Remove the suction and pressure lines. Unscrew the stoppers from the cylinder heads and release the water.

Oil change: The oil must be changed for the first time after 50 hours of operation, and every 200 hours after that. Do this by removing the oil stopper, turning the pump upside down, and releasing the used oil. Then refill with new oil up to the oil filling stopper (use SAE 30W40 engine oil).

### 9.7.1 Troubleshooting at the Kappa 15 membrane pump

Fault	Rectification
<p>The pressure hoses vibrate. The pointer on the pressure manometer quivers. The pressure is unstable.</p>	<p>Check that the suction pipe between the pump and the reservoir is not excessively bent, that the O-ring is in good condition, and that the groove nut is properly tightened.</p>
	<p>Check the filter. If it is soiled – clean it</p>
	<p>Is the pressure between 5 and 7 bar? If Yes: Pressure is okay If No: Check the pump</p>
	<p>Check the suction pressure valves by loosening the tensioning screws and removing the cylinder heads one after another (which avoids oil loss). Hold the pump in such a way that the membrane is pointing upwards. Check the correct position of the valves before reinserting the cylinder heads.</p>
<p>The pump does supply water, but does not develop pressure any more.</p>	<p>Unscrew the rear plug, and check whether it is possible that foreign bodies are stuck in the pressure valve, see that it is correctly assembled, and check whether the valve plate is worn out. In that case, replace the valve and reinstall it correctly.</p>
<p>A mixture of oil and water forms inside the pump, or the level of lubricant is seen to fall after a few minutes.</p>	<p>Dismantle the cylinder heads, check the membranes. Damaged membranes must be replaced, and the oil must be changed.</p> <p><b>Caution:</b> Damaged membranes can lead to the development of excessive pressure inside the pump, and this can cause the oil stoppers to be blown out.</p>